



Special Use Permit #2022-00061
516 Oronoco Street
Oronoco Dental

Application	General Data	
Request: Public Hearing and consideration of a request for a Special Use Permit for the expansion of a health profession office and change in use from a non-complying personal service establishment to a health profession office	Planning Commission Hearing:	October 6, 2022
	City Council Hearing:	October 15, 2022
Address: 516 Oronoco Street	Zone: RM	RM/Townhouse zone
Applicant: Stella Kim	Small Area Plan:	Old Town

Staff Recommendation: APPROVAL subject to compliance with all applicable codes and ordinances and the recommended permit conditions found in Section III of this report.

Staff Reviewers: Patrick Silva, patrick.silva@alexandriava.gov
 Ann Horowitz, ann.horowitz@alexandriava.gov

PLANNING COMMISSION ACTION, OCTOBER 6, 2022: On a motion by Commissioner Lyle, seconded by Vice Chair McMahan, the Planning Commission voted to recommend approval of Special Use Permit #2022-00061, as submitted. The motion carried on a vote 7-0.

PROJECT LOCATION MAP

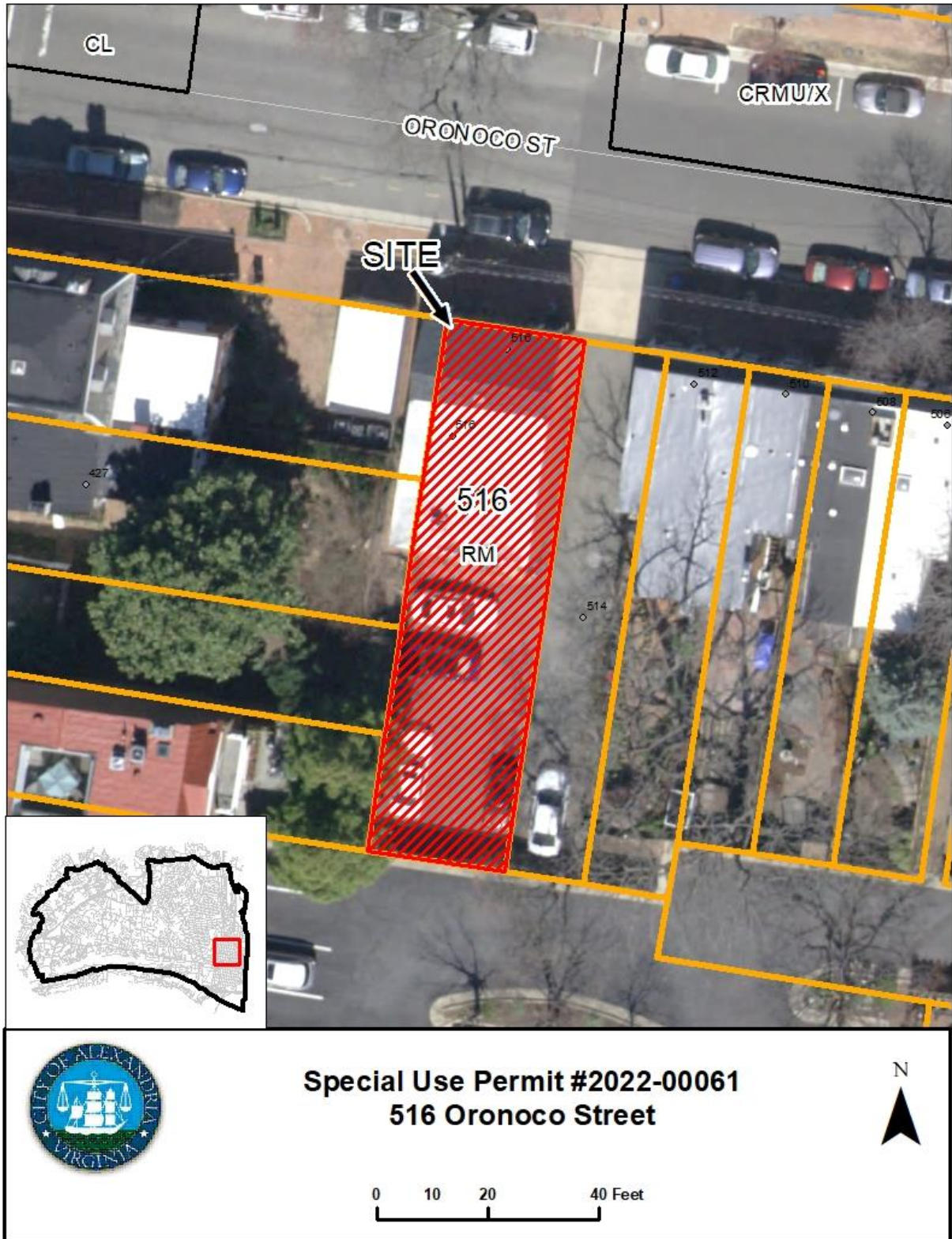

I. DISCUSSION

The applicant, Stella Kim, requests Special Use Permit approval to expand an existing non-complying use in the form of a health profession office and change an existing non-complying use from personal service establishment to health profession office at 516 Oronoco Street.

SITE DESCRIPTION

The subject property is two lots of record with 40.00 feet of frontage on Oronoco Street, 96.58 feet of depth, and a total lot area of 3863.2 square feet. The site is currently developed with a two-story masonry structure (Figure 1). The existing dental office operates on the second floor in 906 square footage of floor area. A five-space parking lot is located at the rear of the property.

The property is surrounded to the north, east, and west by residential townhomes and to the south by the Bulfinch Square Condominiums surface parking lot.



Figure 1 – Subject Site

BACKGROUND

The existing structure is approximately 2,005 square feet in size and was constructed for a two-story dentist office in 1972 when the parcel was zoned C-2/ Commercial. The parcel was zoned RM/Townhouse, a residential zone, in 1992. In March 1995, a certificate of occupancy (OCC95-00071) was issued for a law office (business and professional office) that was to be located on the first floor, replacing the first floor of the dental office, with a separate side entrance addressed as 516 ½ Oronoco. By 2010, a beauty spa (personal service establishment) was also located on the first floor along with the law office. By 2017, the law office had ceased operations on the first floor, although the personal service establishment continued. A dental office maintained its operations on the second floor.

PROPOSAL

The applicant wishes to expand to the first floor and to replace the 906 square foot space, last used as a personal service establishment use, with a health profession office use, both non-complying uses. As a result of the proposed expansion to the first floor, the applicant seeks to establish four additional dental hygiene areas and a waiting room on the first floor (Figure 2).

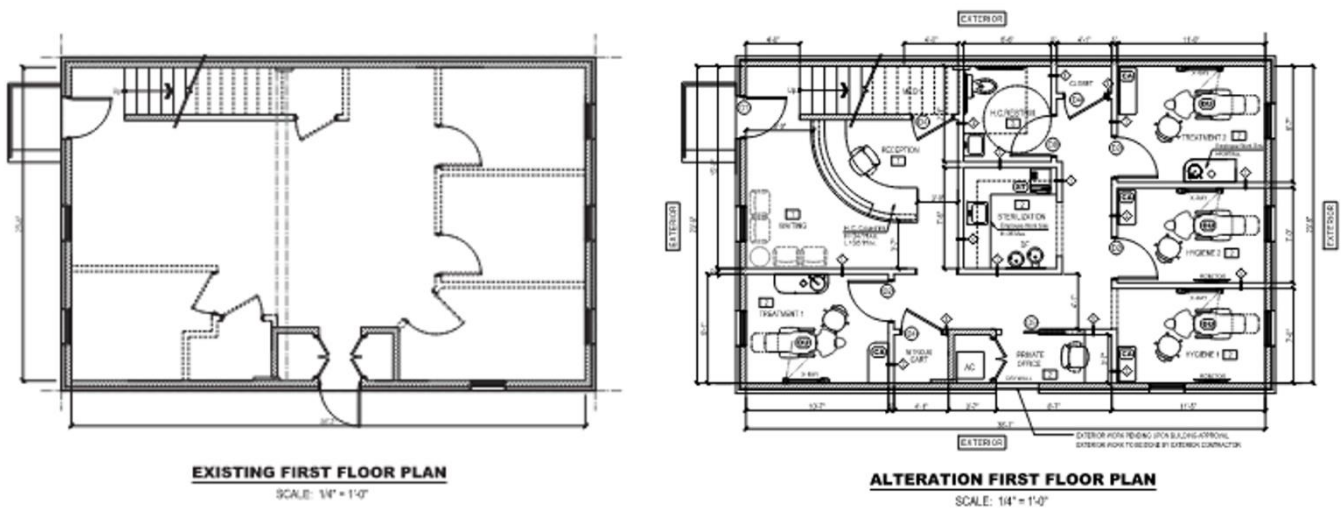

Figure 2 – Existing Conditions and Proposed Conditions.

Details of the applicant’s expanded health profession office operations would be:

Hours of operation: 8:00 a.m. to 5:00 p.m., Monday through Friday (existing)

Number of Employees: Four (existing)

Number of Customers: Approximately 15 customers per day

Noise: No noise impacts anticipated. (existing)

Odors: No odor impacts anticipated. (existing)

Trash/Litter: Private trash removal for general trash. (existing)

ZONING

The subject property is located in the RM/Townhouse zone. Previously, the subject site was zoned C-2/Commercial and in 1992 the property was rezoned to RM/Townhouse, thus rendering the commercial uses present at the subject site non-complying. Section 12-302 of the Zoning Ordinance states that a non-complying use, the health profession office use in this case, may be expanded, intensified, or changed as noted in Sections 12-302(A) and (B)(2):

(A) A special use permit is required for the physical expansion, enlargement, or intensification of a non-complying use.

(B)(2) A non-complying use may be changed, with a special use permit, to any use allowed in the zone in which such a non-complying use is the first listed in this ordinance.

The expansion of the existing non-complying health profession office located on the second floor of the building to the first floor of the building represents an expansion of a non-complying use. Additionally, as it is separately defined in the Zoning Ordinance, a health profession office on the first floor represents a change from the previous non-complying personal service establishment which occupied the space.

The subject property is located within the Old and Historic District. Any exterior changes viewed from the public right-of-way require a Certificate of Appropriateness from the Board of Architectural Review.

MASTER PLAN DESIGNATION

The proposed use is non-complying with the Old Town Small Area Plan chapter of the Master Plan, which designates the property for residential use.

PARKING

Pursuant to Section 8-200(A)(19)(a) of the Zoning Ordinance, a minimum of 0.25 off-street spaces are required per 1,000 square feet of floor area with a maximum of 1.5 spaces per 1,000 square feet of floor area. With a gross floor area of 1,812 square feet, the minimum parking requirement for this use would be two spaces and the maximum would be three spaces. Pursuant to Section 8-100(A)(9) of the Zoning Ordinance, nonresidential uses that have a minimum parking requirement of two spaces or less shall be exempt from providing the spaces. Although the maximum parking requirement is exceeded with the presence of the five-space surface parking lot, the two extra parking spaces may remain as they are existing.

II. STAFF ANALYSIS

Staff supports the applicant's request to expand an existing non-complying health profession office and change an existing non-complying use, the personal service establishment, to a health profession office. The existing non-complying uses have operated without complaints and a dental office originally operated on both floors of the building for several decades with no negative impacts.

Health profession offices are generally a low-impact commercial use, which tend to generate little to no neighborhood impacts. Street parking would not be impacted as the use provides a rear parking lot for its patrons. Also, the relatively small dental office would be located across the street from another commercial business, the Old Town School for Dogs, serving as a low-impact commercial transition to the residential properties and providing a walkable amenity in a dense residential area.

Regarding the analysis required by Section 12(302)(B)(2), the expansion of a health profession office to the first floor is considered a reasonable change to a non-complying use as it is similar in intensity to a personal service establishment. This finding is derived from noting when the two uses first appear in the Zoning Ordinance commercial zones, generally listed from least intense to

most intense. Given that the health profession office and the personal service establishment are first listed as permitted uses in CL/Commercial Low zone, the health profession office use is of equal intensity to the existing personal service establishment.

Staff has included standard Special Use Permit conditions to mitigate the potential for environmental and parking impacts at the site. Conditions #2, #3, #4, #5, #6, and #7 limit any environmental impacts stemming from noise, trash, odors or pollutants. Likewise, Conditions #8, #9, #10, and #11 reduce traffic or parking impacts by requiring employees to use off-street parking and encouraging patrons to use off-street parking and alternative forms of transportation to the site.

Subject to the conditions stated in Section III of this report, staff recommends approval of the Special Use Permit request.

III. RECOMMENDED CONDITIONS

Staff recommends approval subject to compliance with all applicable codes and ordinances and the following conditions:

1. The Special Use Permit shall be granted to the applicant only or to any business or entity in which the applicant has a controlling interest. (P&Z)
2. Litter on the site and on public rights-of-way and spaces adjacent to or within 75 feet of the premises shall be picked up at least once a day and at the close of business, and more often if necessary, to prevent an unsightly or unsanitary accumulation, on each day that the business is open to the public. (T&ES)
3. Exterior power washing of the building shall not be completed using any kind of detergents. (T&ES)
4. Trash and garbage shall be stored inside or in sealed containers that do not allow odors to escape, invasion by animals, or leaking. No trash or debris shall be allowed to accumulate outside of those containers. (P&Z) (T&ES)
5. The applicant shall control odors, smoke and any other air pollution from operations at the site and prevent them from leaving the property or becoming a nuisance to neighboring properties, as determined by the department of Transportation and Environmental Services. (T&ES)
6. All waste products including but not limited to organic compounds (solvents and cleaners) shall be disposed of in accordance with all local, state and federal ordinances or regulations. (T&ES)

7. Supply deliveries, loading, and unloading activities shall not occur between the hours of 11:00pm and 7:00am. (T&ES)
8. The applicant shall require its employees who drive to use off-street parking. (T&ES)
9. The applicant shall encourage its employees to use public transportation to travel to and from work. The business shall contact Go Alex at goalex@alexandriava.gov for information on establishing an employee transportation benefits program. (T&ES)
10. The applicant shall provide information about alternative forms of transportation to access the site, including but not limited to printed and electronic business promotional material, posting on the business website, and other similar methods. Contact Go Alex at goalex@alexandriava.gov for more information about available resources. (T&ES)
11. The applicant shall encourage patrons to park off-street through the provision of information about nearby garages or lots in the business' advertising and website. (T&ES)
12. The Director of Planning and Zoning shall review the Special Use Permit one year after approval and shall docket the matter for consideration by the Planning Commission and City Council if (a) there have been documented violations of the permit conditions which were not corrected immediately, constitute repeat violations or which create a direct and immediate adverse zoning impact on the surrounding community; (b) the Director has received a request from any person to docket the permit for review as a result of a complaint that rises to the level of a violation; or (c) the Director has determined that there are problems with the operation of the use and that new or revised conditions are needed. (P&Z)

STAFF:

Tony LaColla, AICP, Division Chief
Ann Horowitz, Principal Planner
Patrick Silva, Urban Planner

Staff Note: In accordance with Section 11-506(c) of the Zoning Ordinance, construction or operation shall be commenced and diligently and substantially pursued within 18 months of the date of granting of a special use permit by City Council or the special use permit shall become void.

IV. CITY DEPARTMENT COMMENTS

Legend: C - code requirement R - recommendation S - suggestion F - finding

Transportation & Environmental Services:

- R-1 Litter on the site and on public rights-of-way and spaces adjacent to or within 75 feet of the premises shall be picked up at least once a day and at the close of business, and more often if necessary, to prevent an unsightly or unsanitary accumulation, on each day that the business is open to the public. (T&ES)
- R-2 Exterior power washing of the building shall not be completed using any kind of detergents. (T&ES)
- R-3 Trash and garbage shall be stored inside or in sealed containers that do not allow odors to escape, invasion by animals, or leaking. No trash or debris shall be allowed to accumulate outside of those containers. (P&Z) (T&ES)
- R-4 The applicant shall control odors, smoke and any other air pollution from operations at the site and prevent them from leaving the property or becoming a nuisance to neighboring properties, as determined by the department of Transportation and Environmental Services. (T&ES)
- R-5 All waste products including but not limited to organic compounds (solvents and cleaners) shall be disposed of in accordance with all local, state and federal ordinances or regulations. (T&ES)
- R-6 Supply deliveries, loading, and unloading activities shall not occur between the hours of 11:00pm and 7:00am. (T&ES)
- R-7 The applicant shall require its employees who drive to use off-street parking. (T&ES)
- R-8 The applicant shall encourage its employees to use public transportation to travel to and from work. The business shall contact Go Alex at goalex@alexandriava.gov for information on establishing an employee transportation benefits program. (T&ES)
- R-9 The applicant shall provide information about alternative forms of transportation to access the site, including but not limited to printed and electronic business promotional material, posting on the business website, and other similar methods. Contact Go Alex at goalex@alexandriava.gov for more information about available resources. (T&ES)
- R-10 The applicant shall encourage patrons to park off-street through the provision of information about nearby garages or lots in the business' advertising and website. (T&ES)

- C-1 The applicant shall comply with the City of Alexandria's Solid Waste Control, Title 5, Chapter 1, which sets forth the requirements for the recycling of materials (Sec. 5-1-99). In order to comply with this code requirement, the applicant shall provide a completed Recycling Implementation Plan (RIP) Form within 60 days of SUP approval. Contact the City's Recycling Program Coordinator at (703) 746-4410, or via e-mail at commercialrecycling@alexandriava.gov, for information about completing this form. (T&ES)
- C-2 The applicant shall comply with the City of Alexandria's Noise Control Code, Title 11, Chapter 5, which sets the maximum permissible noise level as measured at the property line. (T&ES)
- C-3 Section 5-1-42- Collection by Private collectors. (c) Time of collection. Solid waste shall be collected from all premises not serviced by the city at least once each week. No collections may be made between the hours of 11:00 p.m. and 7:00 a.m. (6:00 a.m. from May 1, through September 30) if the collection area is less than 500 feet from a residential area. (T&ES)

Code Enforcement:

C-1 Building permit review is required.

Fire:

No comments or concerns.

Police:

No comments received.

Park & Recreation:

No comments received.



APPLICATION

SPECIAL USE PERMIT

SPECIAL USE PERMIT # _____

PROPERTY LOCATION: 516 Oronoco St Alexandria, VA 22314

TAX MAP REFERENCE: 064.02-10-04 **ZONE:** RM

APPLICANT:

Name: Stella Kim

Address: 516 Oronoco St Alexandria, VA 22314

PROPOSED USE: Dental office

- THE UNDERSIGNED, hereby applies for a Special Use Permit in accordance with the provisions of Article XI, Section 4-11-500 of the 1992 Zoning Ordinance of the City of Alexandria, Virginia.
- THE UNDERSIGNED, having obtained permission from the property owner, hereby grants permission to the City of Alexandria staff and Commission Members to visit, inspect, and photograph the building premises, land etc., connected with the application.
- THE UNDERSIGNED, having obtained permission from the property owner, hereby grants permission to the City of Alexandria to post placard notice on the property for which this application is requested, pursuant to Article IV, Section 4-1404(D)(7) of the 1992 Zoning Ordinance of the City of Alexandria, Virginia.
- THE UNDERSIGNED, hereby attests that all of the information herein provided and specifically including all surveys, drawings, etc., required to be furnished by the applicant are true, correct and accurate to the best of their knowledge and belief. The applicant is hereby notified that any written materials, drawings or illustrations submitted in support of this application and any specific oral representations made to the Director of Planning and Zoning on this application will be binding on the applicant unless those materials or representations are clearly stated to be non-binding or illustrative of general plans and intentions, subject to substantial revision, pursuant to Article XI, Section 11-207(A)(10), of the 1992 Zoning Ordinance of the City of Alexandria, Virginia.

Stella Kim
 Print Name of Applicant or Agent

516 Oronoco St
 Mailing/Street Address

Alexandria, VA 22314
 City and State Zip Code

[Signature] 07/11/2022
 Signature Date

703-549-1960 _____
 Telephone # Fax #

oronocodental@gmail.com
 Email address

PROPERTY OWNER'S AUTHORIZATION

As the property owner of 516 Oronoco St Alexandria, VA 22314, I hereby
(Property Address)

grant the applicant authorization to apply for the dental office use as
(use)

described in this application.

Name: Stella Kim

Phone 917 - 763 - 9970

Please Print

Address: 3143 Eakin Park CT Fairfax, VA 22031

Email: oronocodental@gmail.com

Signature: 

Date: 07/11/2022

1. Floor Plan and Plot Plan. As a part of this application, the applicant is required to submit a floor plan and plot or site plan with the parking layout of the proposed use. The SUP application checklist lists the requirements of the floor and site plans. The Planning Director may waive requirements for plan submission upon receipt of a written request which adequately justifies a waiver.

Required floor plan and plot/site plan attached.

Requesting a waiver. See attached written request.

2. The applicant is the (check one):

Owner

Contract Purchaser

Lessee or

Other: _____ of the subject property.

State the name, address and percent of ownership of any person or entity owning an interest in the applicant or owner, unless the entity is a corporation or partnership, in which case identify each owner of more than three percent.

Stella Kim = 3143 Eakin Park CT Fairfax, VA 22031 50%.

Nathan Schoenly = 3143 Eakin Park CT Fairfax, VA 22031 50%.

OWNERSHIP AND DISCLOSURE STATEMENT

Use additional sheets if necessary

1. Applicant. State the name, address and percent of ownership of any person or entity owning an interest in the applicant, unless the entity is a corporation or partnership, in which case identify each owner of more than three percent. The term ownership interest shall include any legal or equitable interest held at the time of the application in the real property which is the subject of the application.

	Name	Address	Percent of Ownership
1.	Stella Kim	3143 Eakin Park CT Fairfax, VA 22031	100%
2.			
3.			

2. Property. State the name, address and percent of ownership of any person or entity owning an interest in the property located at 516 Oronoco St Alexandria, VA 22314 (address), unless the entity is a corporation or partnership, in which case identify each owner of more than three percent. The term ownership interest shall include any legal or equitable interest held at the time of the application in the real property which is the subject of the application.

	Name	Address	Percent of Ownership
1.	Stella Kim	3143 Eakin Park CT Fairfax, VA 22031	50%
2.	Nathan Schoenly	3143 Eakin Park CT Fairfax, VA 22031	50%
3.			

3. Business or Financial Relationships. Each person or entity indicated above in sections 1 and 2, with an ownership interest in the applicant or in the subject property are required to disclose any business or financial relationship, as defined by Section 11-350 of the Zoning Ordinance, existing at the time of this application, or within the 12-month period prior to the submission of this application with any member of the Alexandria City Council, Planning Commission, Board of Zoning Appeals or either Boards of Architectural Review. **All fields must be filled out completely. Do not leave blank. (If there are no relationships please indicate each person or entity and "None" in the corresponding fields).**

For a list of current council, commission and board members, as well as the definition of business and financial relationship, [click here](#).

	Name of person or entity	Relationship as defined by Section 11-350 of the Zoning Ordinance	Member of the Approving Body (i.e. City Council, Planning Commission, etc.)
1.	Stella Kim	None	None
2.	Nathan Schoenly	None	None
3.			

NOTE: Business or financial relationships of the type described in Sec. 11-350 that arise after the filing of this application and before each public hearing must be disclosed prior to the public hearings.

As the applicant or the applicant's authorized agent, I hereby attest to the best of my ability that the information provided above is true and correct.

07/11/2022
Date

Stella Kim
Printed Name

Signature

If property owner or applicant is being represented by an authorized agent such as an attorney, realtor, or other person for which there is some form of compensation, does this agent or the business in which the agent is employed have a business license to operate in the City of Alexandria, Virginia?

Yes. Provide proof of current City business license

No. The agent shall obtain a business license prior to filing application, if required by the City Code.

NARRATIVE DESCRIPTION

3. The applicant shall describe below the nature of the request **in detail** so that the Planning Commission and City Council can understand the nature of the operation and the use. The description should fully discuss the nature of the activity. (Attach additional sheets if necessary.)

This project is to extend the existing dentist office on the second adding with 1st floor currently used as
a beauty spa. A floor plan is attached for more details.

USE CHARACTERISTICS

4. The proposed special use permit request is for (check one):

- a new use requiring a special use permit,
 an expansion or change to an existing use without a special use permit,
 an expansion or change to an existing use with a special use permit,
 other. Please describe: _____

5. Please describe the capacity of the proposed use:

A. How many patrons, clients, pupils and other such users do you expect?
Specify time period (i.e., day, hour, or shift).

15 patients per day from Monday through Friday. 8AM - 5PM.

B. How many employees, staff and other personnel do you expect?
Specify time period (i.e., day, hour, or shift).

4 employees per day from Monday through Friday. 8AM - 5PM.

6. Please describe the proposed hours and days of operation of the proposed use:

Day:

Hours:

Monday through Friday

8 AM to 5 PM

7. Please describe any potential noise emanating from the proposed use.

A. Describe the noise levels anticipated from all mechanical equipment and patrons.

Minimal to none

B. How will the noise be controlled?

N/A

8. Describe any potential odors emanating from the proposed use and plans to control them:

Minimal to none.

9. Please provide information regarding trash and litter generated by the use.

A. What type of trash and garbage will be generated by the use? (i.e. office paper, food wrappers)
office paper, used PPE (ex. gloves, masks, plastic barriers),
biologic waste is managed by Stericycle.

B. How much trash and garbage will be generated by the use? (i.e. # of bags or pounds per day or per week)
5 bags per week

C. How often will trash be collected?
weekly

D. How will you prevent littering on the property, streets and nearby properties?
Litter is managed by the staff and owner on a
daily basis.

10. Will any hazardous materials, as defined by the state or federal government, be handled, stored, or generated on the property?

Yes. No.

If yes, provide the name, monthly quantity, and specific disposal method below:

Sharps, 120 per month, Stericycle pick up quarterly.

11. Will any organic compounds, for example paint, ink, lacquer thinner, or cleaning or degreasing solvent, be handled, stored, or generated on the property?

Yes. No.

If yes, provide the name, monthly quantity, and specific disposal method below:

N/A

12. What methods are proposed to ensure the safety of nearby residents, employees and patrons?

All sharps are deposited into sharps containers
then picked up by Stericycle safely.

ALCOHOL SALES

13.

A. Will the proposed use include the sale of beer, wine, or mixed drinks?

Yes No

If yes, describe existing (if applicable) and proposed alcohol sales below, including if the ABC license will include on-premises and/or off-premises sales.

N/A

PARKING AND ACCESS REQUIREMENTS N/A

14. A. How many parking spaces of each type are provided for the proposed use:

- _____ Standard spaces
- _____ Compact spaces
- _____ Handicapped accessible spaces.
- _____ Other.

Planning and Zoning Staff Only
Required number of spaces for use per Zoning Ordinance Section 8-200A _____
Does the application meet the requirement? [] Yes [] No

B. Where is required parking located? (check one)

- [] on-site
- [] off-site

If the required parking will be located off-site, where will it be located?

PLEASE NOTE: Pursuant to Section 8-200 (C) of the Zoning Ordinance, commercial and industrial uses may provide off-site parking within 500 feet of the proposed use, provided that the off-site parking is located on land zoned for commercial or industrial uses. All other uses must provide parking on-site, except that off-street parking may be provided within 300 feet of the use with a special use permit.

C. If a reduction in the required parking is requested, pursuant to Section 8-100 (A) (4) or (5) of the Zoning Ordinance, complete the PARKING REDUCTION SUPPLEMENTAL APPLICATION.

[] **Parking reduction requested; see attached supplemental form**

15. Please provide information regarding loading and unloading facilities for the use:

A. How many loading spaces are available for the use? N/A

Planning and Zoning Staff Only
Required number of loading spaces for use per Zoning Ordinance Section 8-200 _____
Does the application meet the requirement? [] Yes [] No

B. Where are off-street loading facilities located? n/a

C. During what hours of the day do you expect loading/unloading operations to occur?
N/A

D. How frequently are loading/unloading operations expected to occur, per day or per week, as appropriate?
N/A

16. Is street access to the subject property adequate or are any street improvements, such as a new turning lane, necessary to minimize impacts on traffic flow?

There is no change in occupancy or parking

SITE CHARACTERISTICS

17. Will the proposed uses be located in an existing building? Yes No
Do you propose to construct an addition to the building? Yes No
How large will the addition be? N/A square feet.

18. What will the total area occupied by the proposed use be?
906 sq. ft. (existing) + 0 sq. ft. (addition if any) = 906 sq. ft. (total)

19. The proposed use is located in: *(check one)*
 a stand alone building
 a house located in a residential zone
 a warehouse
 a shopping center. Please provide name of the center: _____
 an office building. Please provide name of the building: _____
 other. Please describe: _____

End of Application



Department of Planning & Zoning
Special Use Permit Application Checklist

Supplemental application for the following uses:

- Automobile Oriented
- Parking Reduction
- Signs
- Substandard Lot
- Lot modifications requested with SUP use

Interior Floor Plan

- Include labels to indicate the use of the space (doors, windows, seats, tables, counters, equipment)

If Applicable

- Plan for outdoor uses

Contextual site image

- Show subject site, on-site parking area, surrounding buildings, cross streets

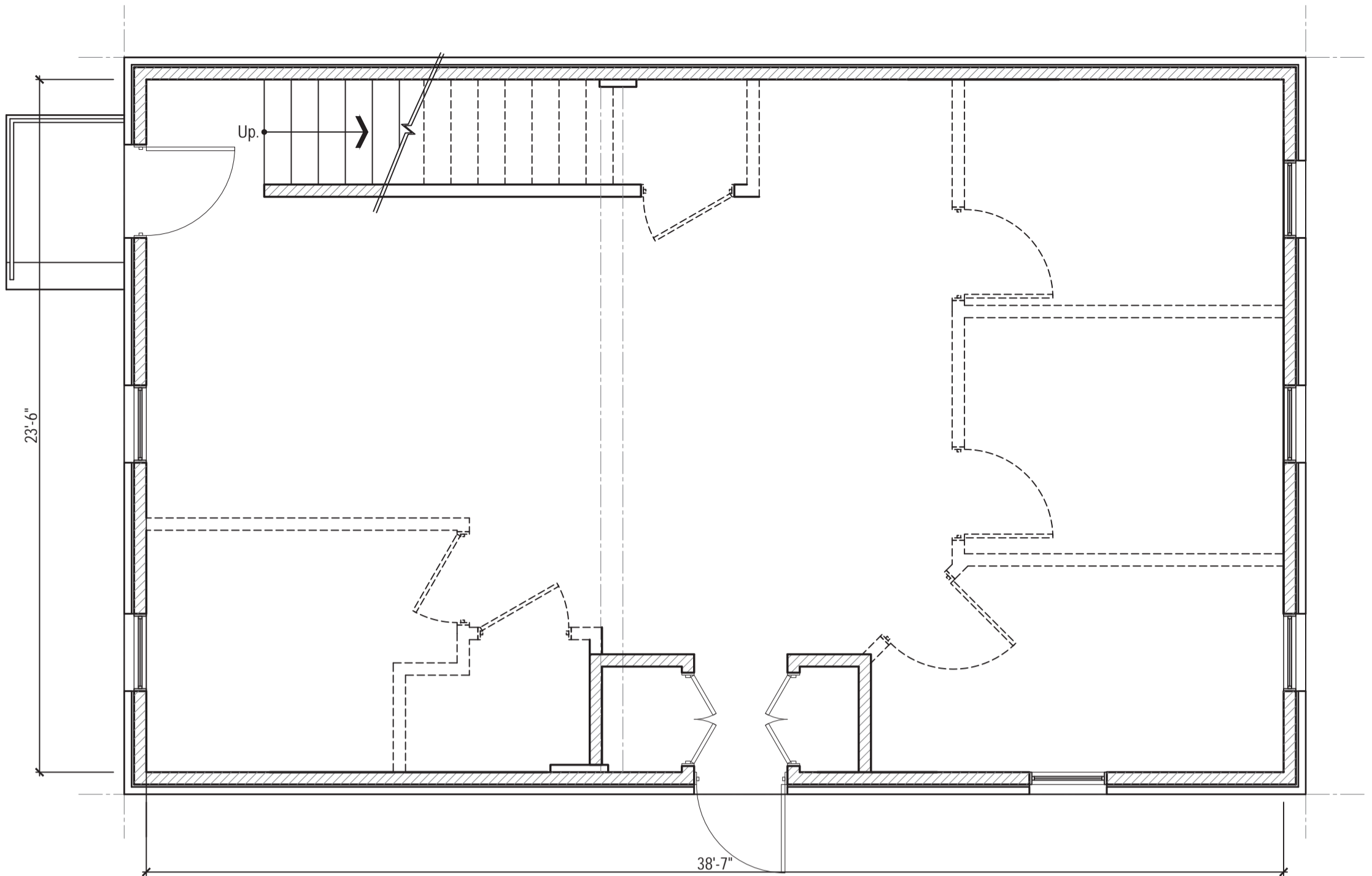

EXISTING FIRST FLOOR PLAN

SCALE: 1/4" = 1'-0"

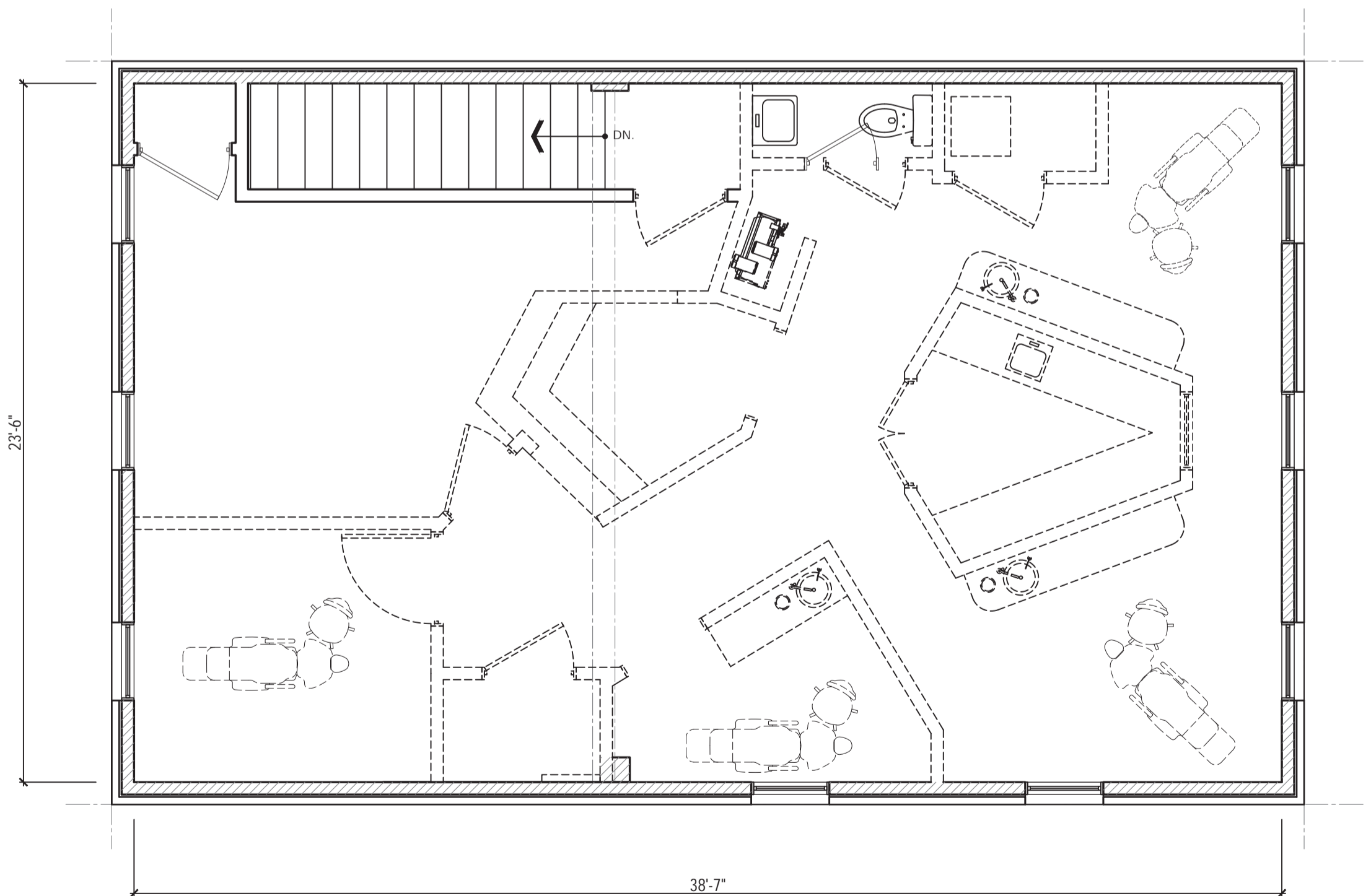

EXISTING SECOND FLOOR PLAN

SCALE: 1/4" = 1'-0"

LINE TYPES:

- BOUNDARY LINE
- - - - EASEMENT
- DRIVEWAY/ROAD
- x - x - FENCING
- OVERHEAD WIRE
- STRUCTURE

LEGEND:

- ADW-ASPHALT DRIVEWAY
- A/C-AIR CONDITIONING
- A/W-AREAWAY
- B.E.-BASEMENT ENTRANCE
- BRL-BUILDING RESTRICTION LINE
- CDW-CONCRETE DRIVEWAY
- CM- CONCRETE MONUMENT
- CONC.-CONCRETE
- DHS-DRILL HOLE SET

- ENT.-ENTRY WAY
- ER-ELECTRICAL RISER
- F.E.-FIRE ESCAPE
- FIOS-FIBER OPTICS UTILITY BOX
- GDW-GRAVEL DRIVEWAY
- IPF-IRON PIPE FOUND
- IRS- IRON ROD SET
- IRF-IRON ROD FOUND
- LA.-LANDING
- MH-MANHOLE
- PAD-CONCRETE PAD

- P.-PORCH
- PL.-PLANTER
- PP-POWER POLE
- R/W-RIGHT OF WAY
- SMH-SANITARY MANHOLE
- ST.-STOOP
- TELE-TELEPHONE PEDESTAL
- TR/TRANS-TRANSFORMER
- W.-WALK
- WM-WATER METER
- W.W-WINDOW WELL

TOTAL AREA= 3,863 SF

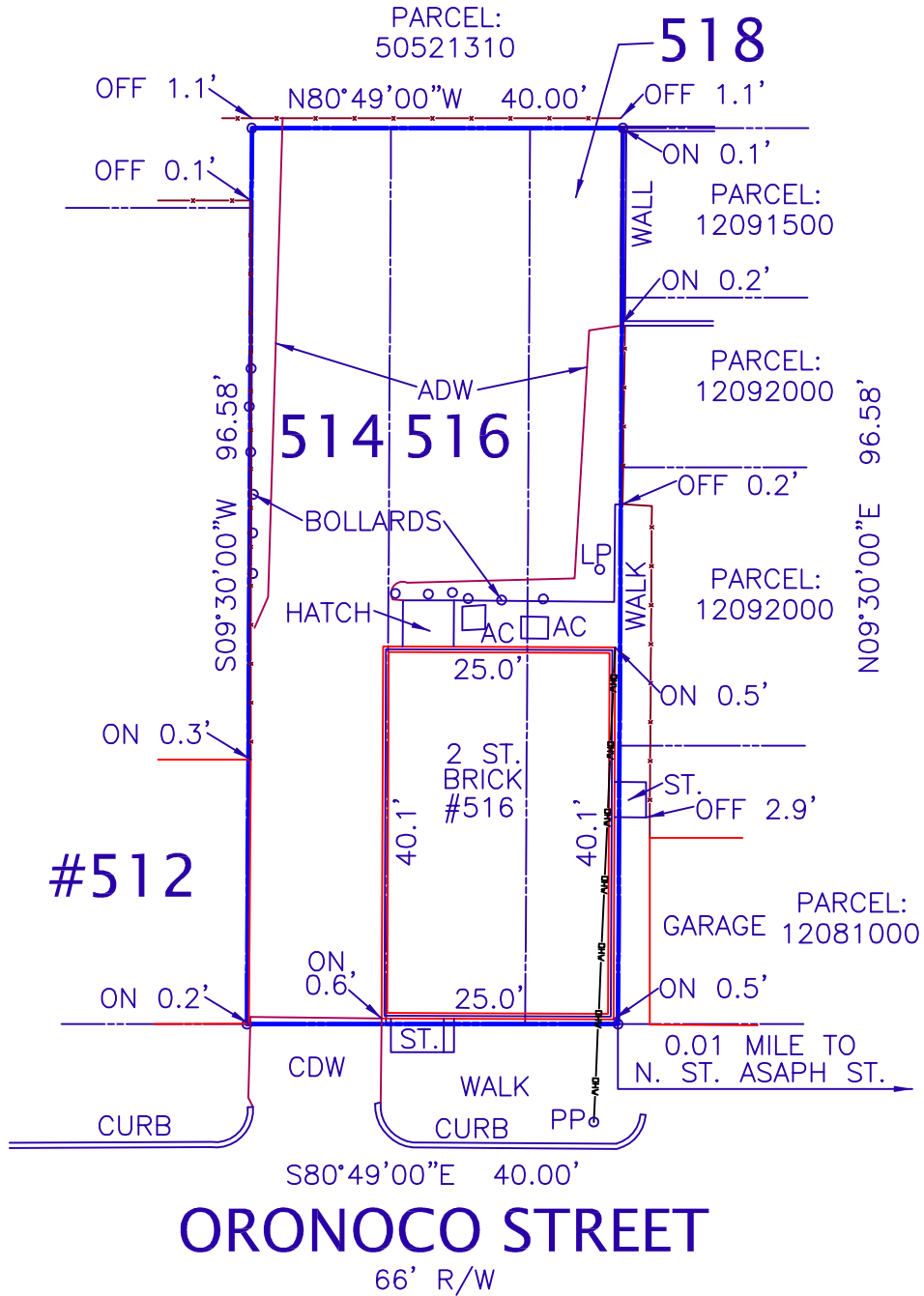

PLAT
 SHOWING LOCATION SURVEY ON
 #514, 516, & 518
ORONOCO STREET
 CITY OF ALEXANDRIA, VIRGINIA
 SCALE: 1" = 20' JANUARY 12, 2022

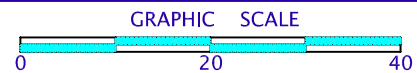

BY PROVISIONS OF THE VIRGINIA CODE: NO CORNER MARKERS SET.
 BOUNDARY SURVEY NOT PERFORMED.
 PLAT SUBJECT TO RESTRICTIONS OF RECORD, TITLE REPORT NOT FURNISHED.

I HEREBY CERTIFY THAT THE POSITIONS OF ALL THE EXISTING IMPROVEMENTS HAVE BEEN CAREFULLY ESTABLISHED BY A CURRENT FIELD SURVEY, AND UNLESS OTHERWISE SHOWN, THERE ARE NO VISIBLE ENCROACHMENTS.

REQUESTED BY:
 LP TITLE, LLC

ALEXANDRIA SURVEYS, LLC
 1229 GARRISONVILLE ROAD SUITE 105B STAFFORD, VA 22556
 TEL. NO. 703-636-1313 FAX NO. 703-636-4266



AURORA ARCHITECTS L.L.C.
ARCHITECTURE DESIGN & CONSULTING

22806 WELBORNE MANOR SQ
ASHBURN, VIRGINIA 20148
PHONE: 571-247-5533
571-247-5534
Email: auroaraarchitects@yahoo.com

© 2011 Aurora Architects, L.L.C. Expressly reserves its common law copyright and other property rights in these plans and to the reproduction, change, or copied in whole or in part in any form or manner whatsoever, nor are they to be assigned to any third party, without first obtaining the express written permission and consent of Aurora Architects, L.L.C.

SEAL & SIGNATURE



Dang Nguyen
Digitally signed by Dang Nguyen
Date: 2022.06.26 17:43:59 -0400

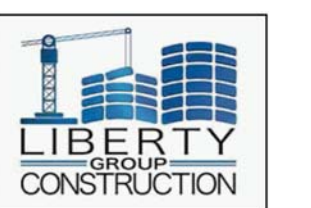

330-E N STONESTREET AVE.
ROCKVILLE, MD 20850
WEB SITE: WWW.LIBERTYCD.COM

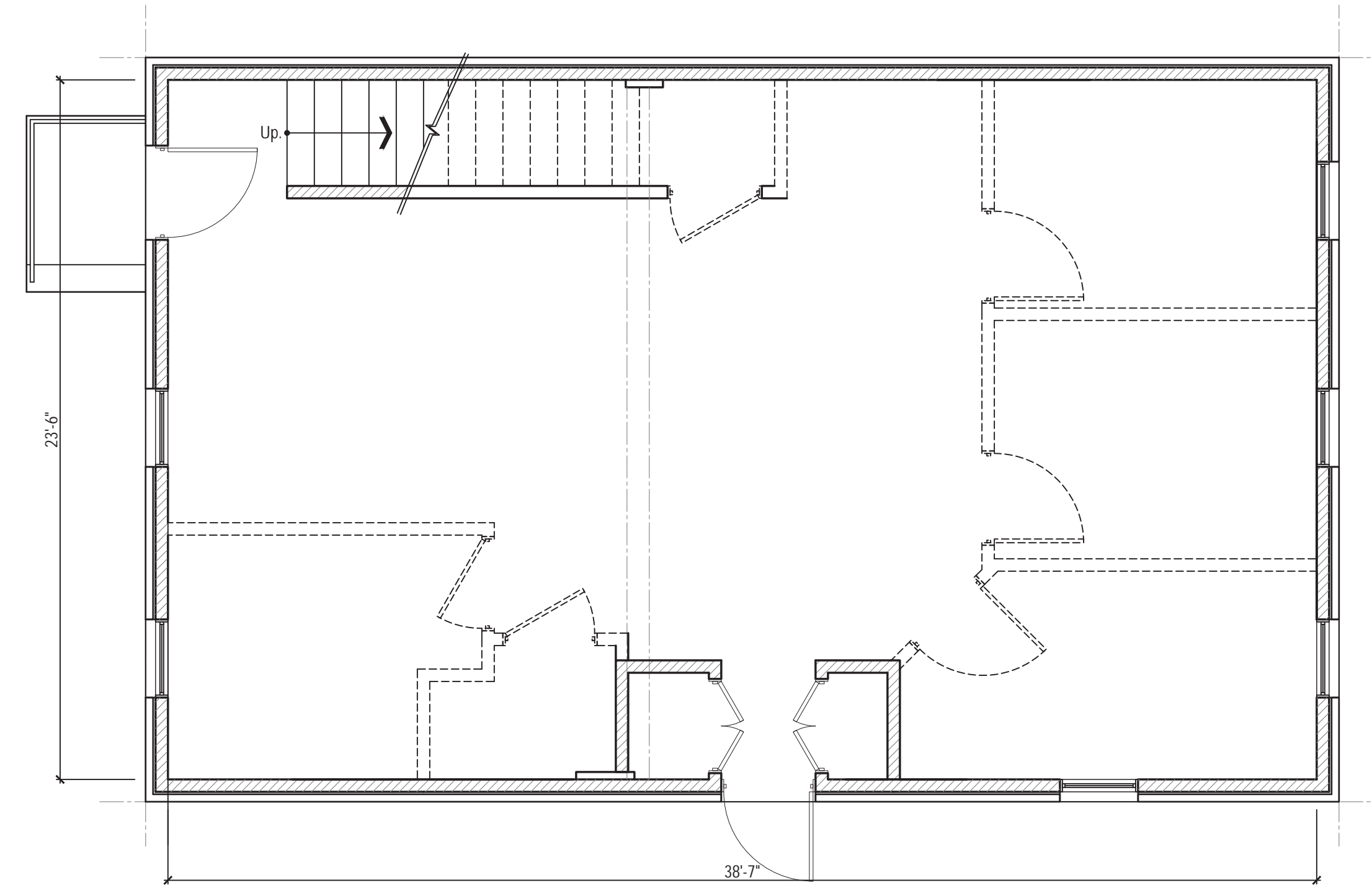

EXISTING FIRST FLOOR PLAN

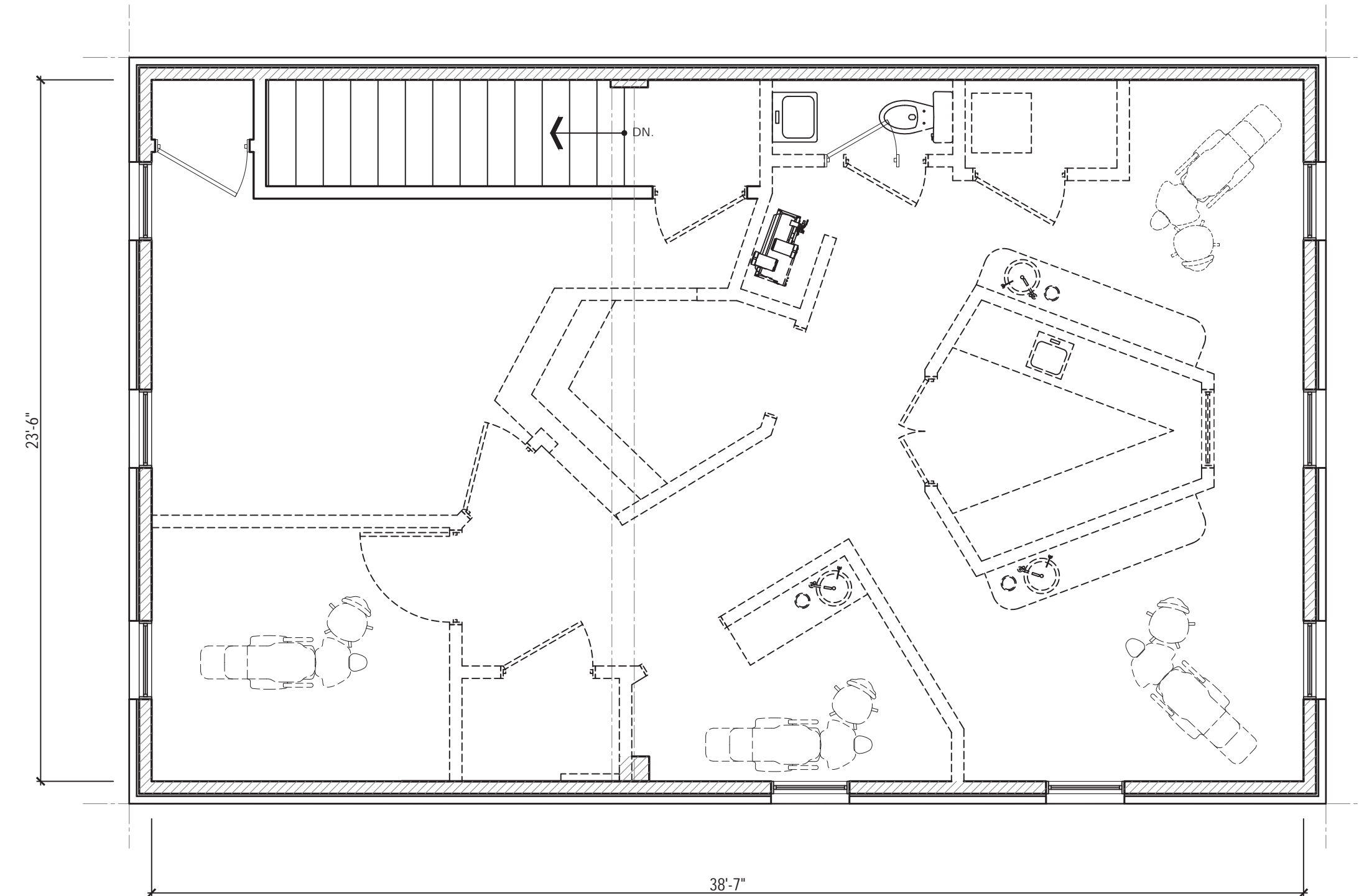

SCALE: 1/4" = 1'-0"



EXISTING SECOND FLOOR PLAN

SCALE: 1/4" = 1'-0"

LEGEND:

-  EXISTING PARTITIONS TO REMAIN
-  EXISTING PARTITIONS TO BE REMOVED

ORONOCO DENTAL

516 ORONOCO STREET
ALEXANDRIA, VA 22314

OWNER: DR. STELLA KIM
PHONE:

ISSUE DATE	DESCRIPTION



PROJECT NUMBER	06.22.002
DRAWN	DN
CHECKED	HN
DATE	6/3/2022
SCALE	AS INDICATED

EXISTING FLOOR PLANS

DRAWING TITLE

A.002

DRAWING No.

TYP. INTERIOR PARTITION 1

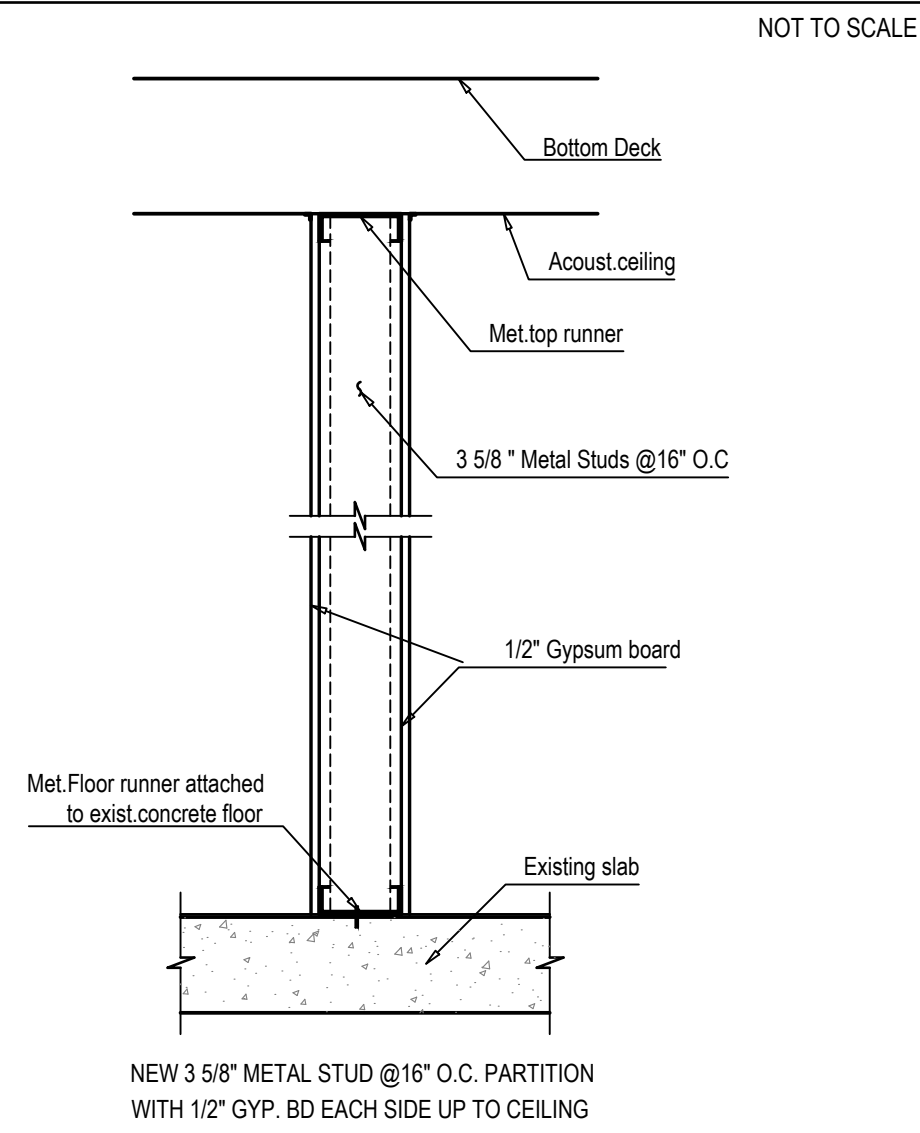

CARPENTRY SYMBOLS

- DU** DENTAL UNIT
- PX** PANORAMIC X-RAY
- XR** X-RAY (SELF-CONTAINED)
- ST** STERILIZER - AUTO CLAVE
- MT** MODEL TRIMMER
- CA** 12 O'CLOCK CABINET UNIT

NOTES FOR CONTRACTOR:

1. ALL EQUIPMENTS SHOULD BE PROVIDED BY DENTAL EQUIPMENT COMPANY. CONTRACTOR SHALL HAVE TO CHECK ALL DRAWINGS FROM DENTAL EQUIPMENT COMPANY FOR INSTRUCTIONS, REQUIREMENTS, DETAILS... AND EXISTING CONDITION BEFORE INSTALL EQUIPMENTS.

DRAWING SYMBOLS & MATERIALS

- 1** ROOM NUMBER TAG
- 1** REVISION TAG
- 1** WALL TAG
- D/W** DOOR/WINDOW NUMBER TAG
- 1** REVISION CLOUD

ADA RESTROOM DETAIL

NOTE : EACH RESTROOM SHALL HAVE HAND SOAP DISPENSER, PAPER TOWEL DISPENSER AND TRASH CAN.

NOT TO SCALE

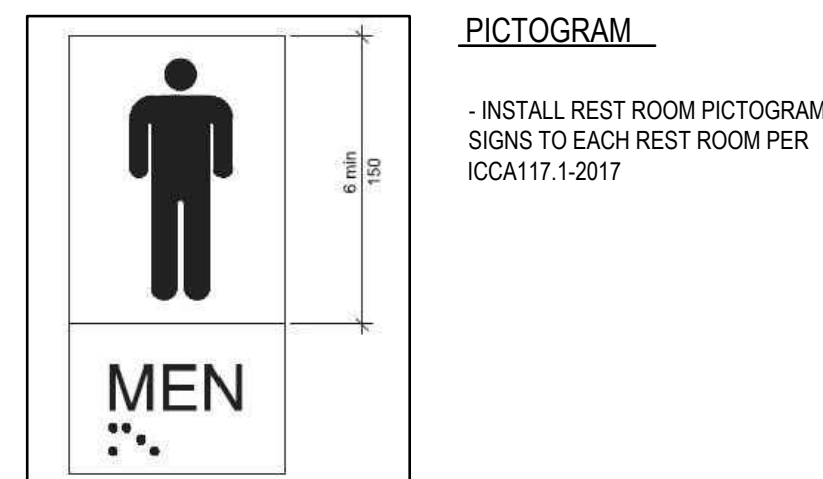
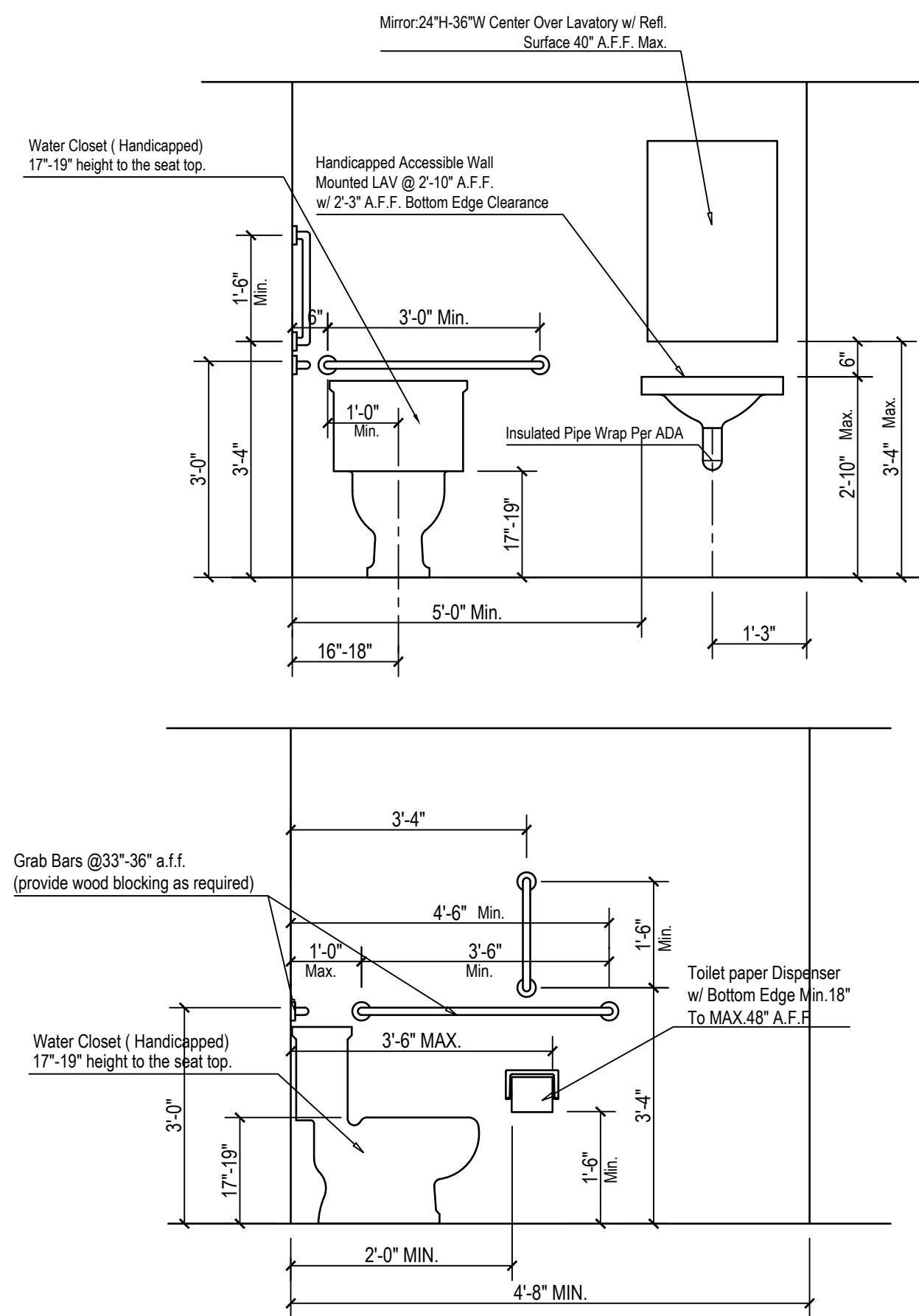

ADA HAND SINK

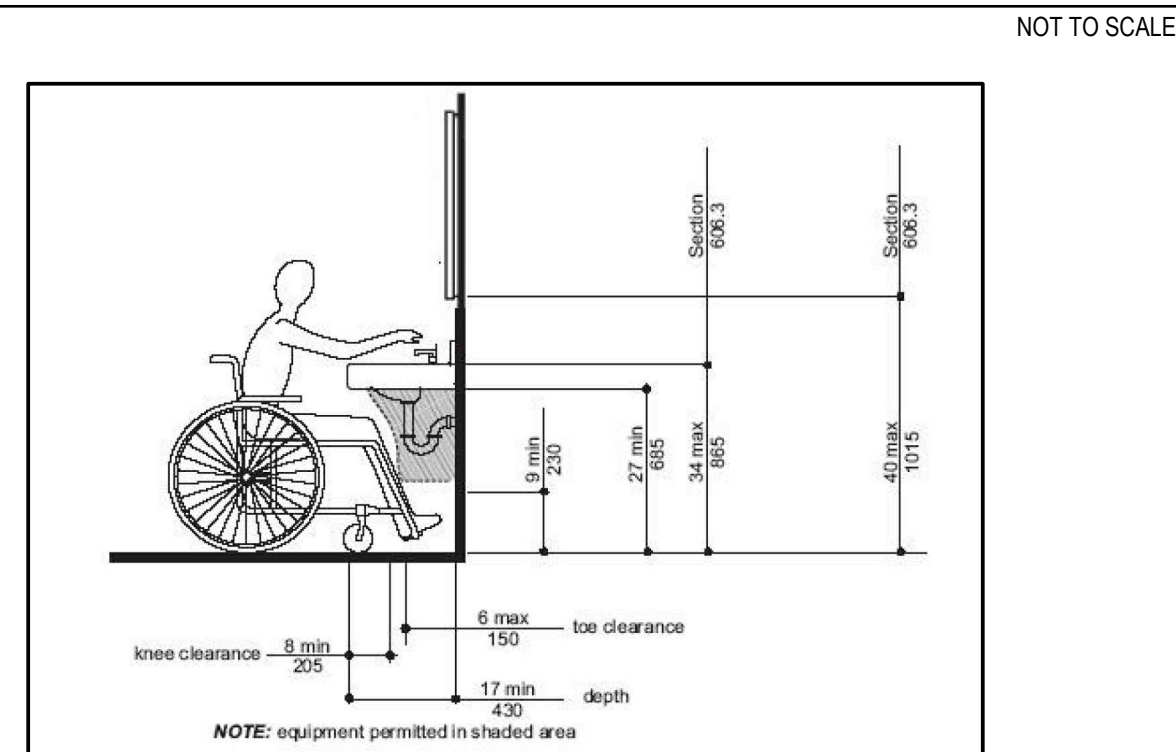

LEGEND:

- EXISTING PARTITIONS TO REMAIN
- NEW PARTITIONS

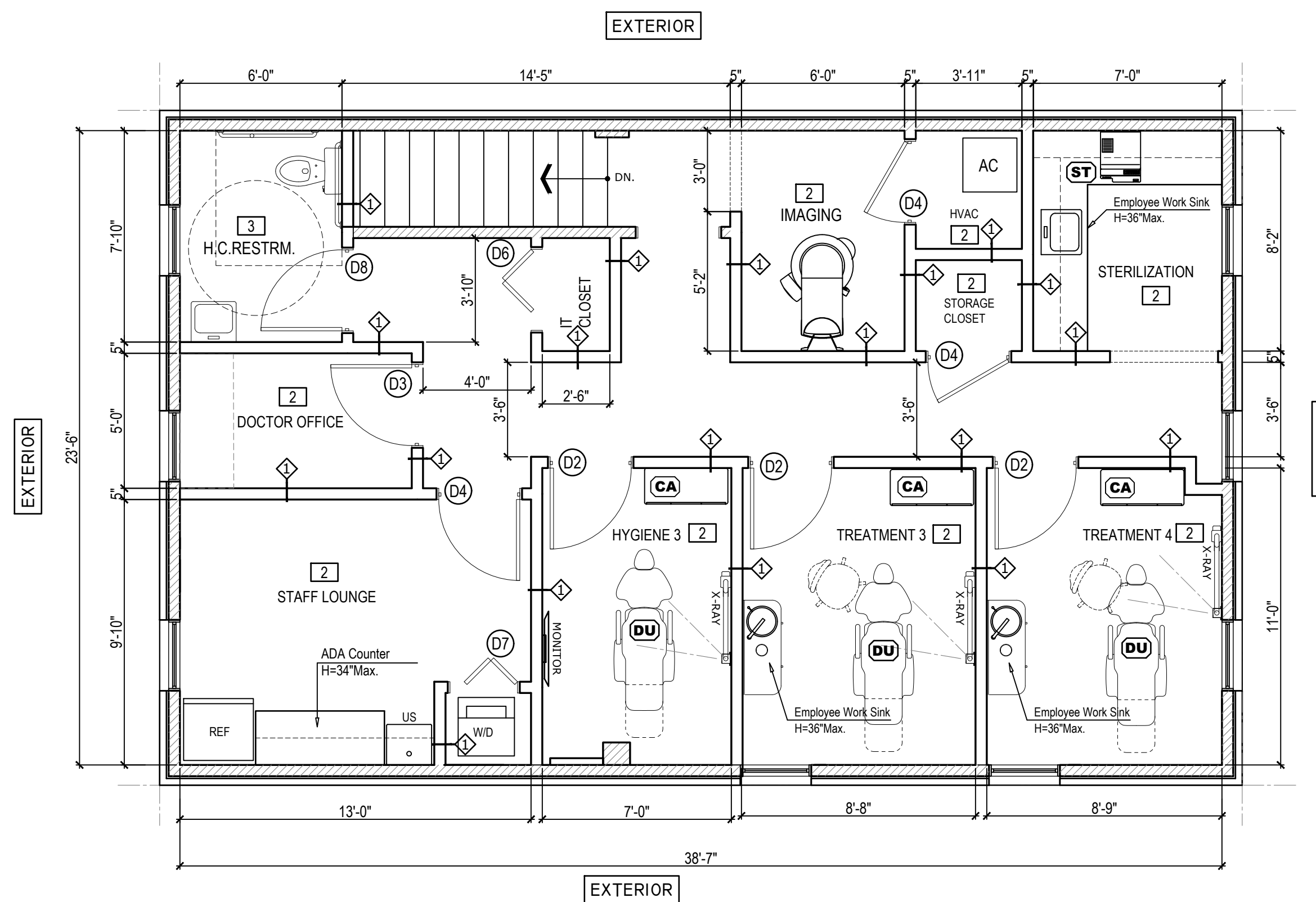
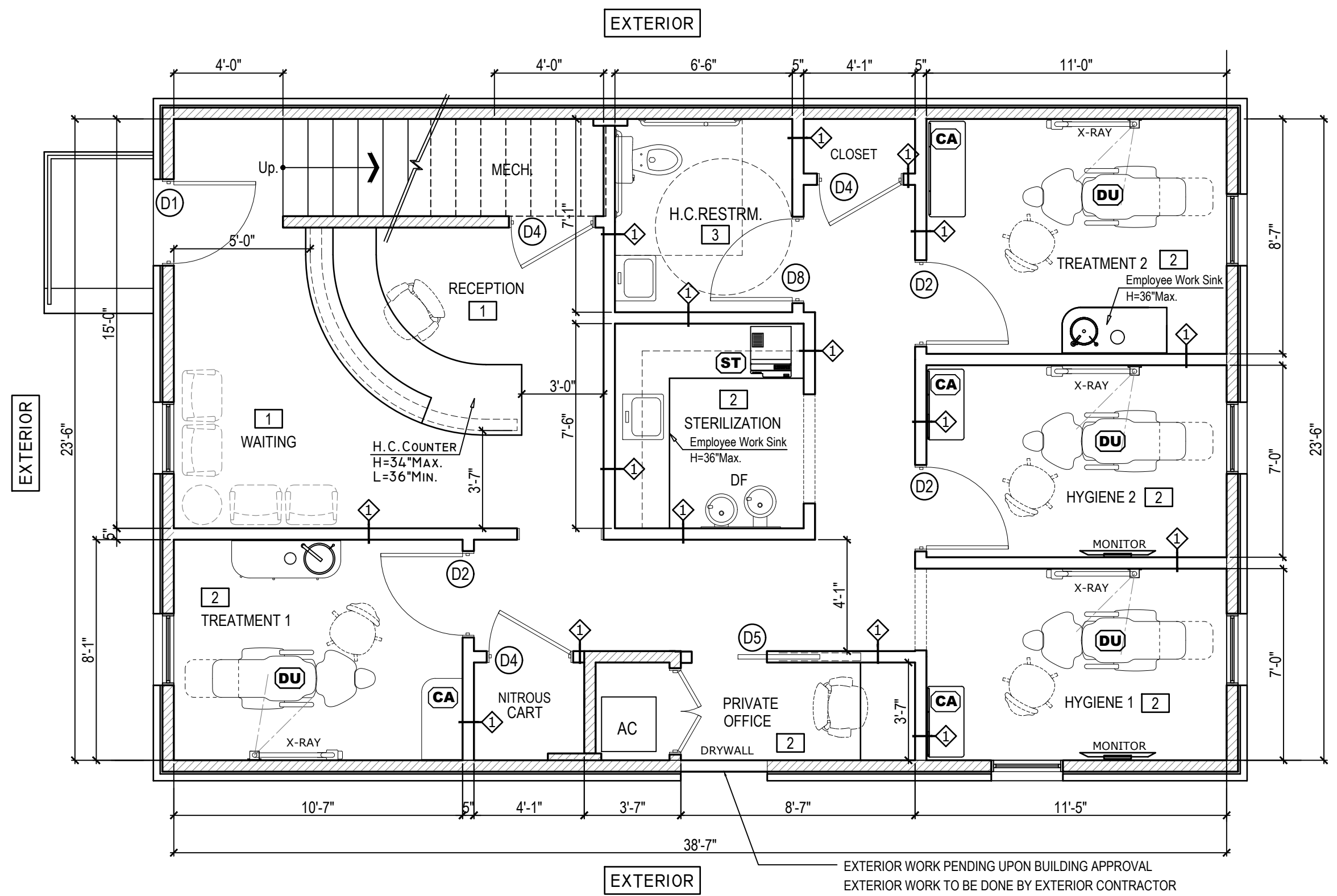

AURORA ARCHITECTS LLC.

ARCHITECTURE DESIGN & CONSULTING

22806 WELBORNE MANOR SQ

ASHBURN, VIRGINIA 20148

PHONE: 571-247-5533

571-247-5534

Email: auroraarchitects@yahoo.com

© 2011 Aurora Architects, L.L.C. Expressly reserves its common law copyright and other property rights in these plans and to the reproduction, change or copied in whole or in part in any form or manner whatsoever, nor are they to be assigned to any third party, without first obtaining the express written permission and consent of Aurora Architects, L.L.C.

SEAL & SIGNATURE



330-N STONESTREET AVE.
ROCKVILLE, MD 20850
WEB SITE: WWW.LIBERTYCD.COM

ORONOCO DENTAL

516 ORONOCO STREET
ALEXANDRIA, VA 22314

OWNER: DR. STELLA KIM
PHONE:

ISSUE

DATE DESCRIPTION

SCALE: 1/4" = 1'-0"

1 2 3 4 6'

PROJECT NUMBER 06.22.002

DRAWN DN

CHECKED HN

DATE 6/3/2022

SCALE AS INDICATED

TENANT LAYOUT PLANS

TYP. PARTITIONS

ADA RESTROOM

DRAWING TITLE

A.003

DRAWING No.