

Docket Item # 4 & 5
BAR CASE # 2013-0134 & 0135
BAR Meeting
May 22, 2013

ISSUE: Permit to Demolish/Capsulate and Certificate of Appropriateness for
Addition/Alterations

APPLICANT: William Cromley

LOCATION: 224 North Fayette Street

ZONE: CRMU/M / Commercial Residential Mixed Use

STAFF RECOMMENDATION: Staff recommends approval of the application with the following conditions:

- That the same exposure of fiber cement shingles and siding be used on the addition and the original building so that the two materials align;
- That the deck, stoop and handicap ramp railings be compatible with the craftsman-style details on the building; and,
- That a canopy may be installed over the new French doors on the rear elevation, subject to BAR Staff approval.

*EXPIRATION OF APPROVALS NOTE: In accordance with Sections 10-106(B) and 10-206(B) of the Zoning Ordinance, any official Board of Architectural Review approval will expire 12 months from the date of final approval if the work is not commenced and diligently and substantially pursued by the end of that 12-month period.

**BUILDING PERMIT NOTE: Most projects approved by the Board of Architectural Review require the issuance of one or more construction permits by Building and Fire Code Administration (including signs). The applicant is responsible for obtaining all necessary construction permits after receiving Board of Architectural Review approval. Contact Code Administration, Room 4200, City Hall, 703-746-4200 for further information.



BAR2013-00134 & BAR2013-00135



***Note:** The two reports for 224 North Fayette Street, BAR #2012-0134 (Permit to Demolish/Capsulate) and BAR #2012-0135 (Certificate of Appropriateness) have been combined for clarity and brevity. This item requires a roll call vote.

I. ISSUE:

The applicant is requesting approval of a Permit to Demolish/Capsulate and Certificate of Appropriateness for an addition and alterations at 224 North Fayette Street.

Permit to Demolish/Capsulate

The applicant proposes the following:

- Demolition/capsulation of the south wall of the existing building, with the exception of an 8 foot section at the front of the building.
- Demolition/capsulation of the rear (west) elevation of the building.
- Removal of the chimney on the north roof slope of the existing roof and the retention of the two chimneys on the south slope.

Certificate of Appropriateness

New construction

A new L-shaped, one-story addition will be constructed on the south and rear elevations of the existing building. The addition will measure 15 feet wide by 85 feet long on the south and 8 feet deep on the rear (west). The addition will be set back roughly 8 feet from the front façade of the building, which will allow for the retention of an existing window on the south elevation. A new wood handicap ramp with railing is proposed on the front façade, and an open deck will be constructed off of the rear. The addition will have a low slope shed roof with exposed rafter ends and skylights on the south elevation. The roof will be clad with composite shingles. The eight windows on the addition will be double-hung, aluminum clad windows in a six-over-six configuration. The rear elevation will have a window, a wood-paneled door under the relocated portico from the rear elevation, and a pair of French doors. Although it appears on the drawings that the same siding material is proposed on both the original building and the addition, the applicant intends to install fiber cement shingles on the original portion of the building and smooth fiber cement beveled siding on the addition.

Alterations

The remainder of the building will be rehabilitated and new fiber cement shingles will be used to replicate the recently removed asbestos siding. The craftsman-style door hoods will be retained, as well as the exposed rafter ends. The existing front door is not original and a new wood door with glazing at the top and panels on the bottom will be installed, similar to the door shown on the original building permit plans. Solar panels may be installed on the south slope of the roof. The existing wood windows are in poor condition and will be replaced with aluminum-clad,

double-hung windows in the same muntin configuration as the existing windows. The existing concrete stair on the front facade will be replaced with a new wood stair and railing.

II. HISTORY:

The building at 224 North Fayette Street was built in 1944 as the Carver Nursery School, operated by the City school system for African-American children. In 1950, the building was leased, and ultimately sold, to the American Legion Post, named for William Thomas, the first African-American soldier from Alexandria to be killed in action during World War I. During the segregation era, it served as the only American Legion outpost in Alexandria open to African-Americans. Over the years Legion membership declined and the building was sometimes vacant or rented to a variety of other uses. The building was sold in 2009 to the current owner.

The building was constructed with asbestos shingle siding (recently removed), as well as an asphalt shingle roof, two exposed brick chimneys on the south elevation, and twelve-over-twelve, double-hung wood windows. While very minimal in detailing, the building does have exposed rafter ends and gabled stick style hoods over the centered front, side, and rear entrances in a vernacular craftsman style. While the building has been vacant for a number of years, the original character defining features are still evident.

BAR history

On July 22, 2009, the applicant received BAR approval for a Permit to Demolish (BAR Case #2009-0109). Before the building was demolished, the Board's decision was appealed to City Council, which upheld the Board's decision on October 17, 2009. Subsequently, the City Council appellants sued the City for violating the requirements of the City Code. The suit was settled in 2010, with the condition that the building be made available for sale for a two-year period, and that if it was sold a conservation easement would be recorded to preserve the building. No buyer was found, and in February 2013 the settlement agreement expired, which allows the applicant to demolish the building pursuant to BAR Case #2009-0109.

III. ANALYSIS:

The proposed project complies with Zoning Ordinance requirements.

Permit to Demolish

In considering a Permit to Demolish/Capsulate, the Board must consider the following criteria set forth in the Zoning Ordinance, §10-205(B):

- (1) Is the building or structure of such architectural or historical interest that its removal would be to the detriment of the public interest?
- (2) Is the building or structure of such interest that it could be made into an historic shrine?
- (3) Is the building or structure of such old and unusual or uncommon design, texture, and material that it could not be reproduced or be reproduced only with great difficulty?
- (4) Would retention of the building or structure help preserve and protect an historic place or area of historic interest in the city?

- (5) Would retention of the building or structure promote the general welfare by maintaining and increasing real estate values, generating business, creating new positions, attracting tourists, students, writers, historians, artists, and artisans, attracting new residents, encouraging study and interest in American history, stimulating interest and study in architecture and design, educating citizens in American culture and heritage and making the city a more attractive and desirable place to live?
- (6) Would retention of the building or structure help maintain the scale and character of the neighborhood?

In the opinion of Staff, none of the criteria for demolition and capsulation are met and the Permit to Demolish/Capsulate should be granted. The area proposed for demolition and capsulation is on secondary facades and the removal of this portion of the building does not compromise the character defining features of the original building. As noted above, the applicant has a valid Permit to Demolish for the building that was approved by both the BAR and City Council. In the opinion of Staff, the retention of the building and the construction of a modest addition are preferable to the full-scale demolition of the building.

Addition

Staff has no objection to the new addition, as it clearly reads as a secondary building mass and will be subtly differentiated from the original building through the use of fiber cement clapboard siding. The addition will be setback from the front façade of the original building, which retains an existing window and helps to differentiate the old building from the different size windows in the new construction. Staff's comments are relatively minor and related only to design details, not the addition:

- Although the type of siding used on the addition and original building will be different, the amount of exposure on the siding should be the same so that the seams align between the old and new construction. James Hardie company makes both fiber cement shingles and the smooth lap siding in a 7" exposure, which is similar to the exposure on the asbestos siding previously on the building.
- Although it is not proposed, Staff would have no objection to the installation of a canopy over the French doors in the rear, provided the canopy is architecturally compatible with the other canopies on the building.
- The railing and picket detailing on the front stoop, handicap ramp and rear deck should be consistent and compatible with the style of the original building.

Alterations

Staff commends the applicant for the preservation of the old Carver Nursery School/American Legion Building, which many people in the community support due to the building's history as a neighborhood institution for African Americans. Staff has no objection to the proposed use of modern materials both on the original building and the new construction – the fiber cement shingles and siding, the composite roofing and the aluminum clad windows – which are in keeping with the modern materials used on the building at the time of its construction (asbestos siding and asphalt shingle roof).

Since the applicant was last before the BAR, the Parker-Gray BAR has made significant changes to the Parker-Gray BAR's *Design Guidelines* and regulations, though at the present time commercial buildings are exempt. The most significant change involves the creation of a Period of Architectural Significance and the prioritization of building elevations. Had the same guidelines been applied to this commercial building, which Staff hopes will happen in the near future, the Board would have had a minimal review in this case.

Staff recommends approval of the application with the minor changes discussed above.

STAFF

Stephanie Sample, Historic Preservation Planner
Al Cox, FAIA, Historic Preservation Manager

IV. CITY DEPARTMENT COMMENTS

Legend: C - code requirement R - recommendation S - suggestion F- finding

Code Administration

No comments received.

Transportation and Environmental Services (T&ES)

RECOMMENDATIONS

- R1. Applicant shall be responsible for repairs to the adjacent city right-of-way if damaged during construction activity. (T&ES)
- R2. All improvements to the city right-of-way such as curbing, sidewalk, driveway aprons, etc. must be city standard design. (T&ES)
- R3. No permanent structure may be constructed over any existing private and/or public utility easements. It is the responsibility of the applicant to identify any and all existing easements on the plan. (T&ES)
- R4. The building permit must be approved and issued prior to the issuance of any permit for demolition. (T&ES)

FINDINGS

- F1. After review of the information provided, an approved grading plan is not required at this time. Please note that if any changes are made to the plan it is suggested that T&ES be included in the review. (T&ES)

CITY CODE REQUIREMENTS

- C-1 Roof, surface and sub-surface drains shall be connect to the public storm sewer system, if available, by continuous underground pipe. Where a storm sewer is not available, the applicant must provide a design to mitigate impact of stormwater drainage onto adjacent properties and to the satisfaction of the Director of Transportation & Environmental Services. (5-6-224) (T&ES)
- C-2 The applicant shall comply with the City of Alexandria's Noise Control Code, Title 11, Chapter 5, which sets the maximum permissible noise level as measured at the property line. (T&ES)
- C-3 All secondary utilities serving this site shall be placed underground. (Sec. 5-3-3) (T&ES)
- C-4 The applicant shall comply with the City of Alexandria's Solid Waste Control, Title 5, Chapter 1, which sets forth the requirements for the recycling of materials (Sec. 5-1-99). (T&ES)

- C-5 Any work within or performed from the right-of-way requires a separate permit from T&ES. (Sec. 5-2) (T&ES)

Alexandria Archaeology

- F-1 In Historic Alexandria, Virginia, Street by Street, A Survey of Existing Early Buildings, Ethelyn Cox indicates that an early powder house was present at the southwest corner of Queen and Fayette Streets in the 18th century. The Hopkins Insurance Map shows that structures were present on this property in 1877, and in the early 1940's the City built a nursery school on the lot. Later, this structure was leased and then sold to the American Legion Post, named for William Thomas, the first African American soldier from Alexandria to be killed in action during World War I. Given the lack of intensive development on this property, it is possible some evidence of the powder house (if it extended onto the lot) could remain despite the 19th and 20th-century construction. The lot therefore has the potential to yield archaeological resources which could provide evidence of residential and other activities in the 19th and early 20th centuries and of the highly significant earlier powder house.
- F-2 It is our understanding that this particular project will be limited to cosmetic changes to the existing structure, and therefore will cause no impact to the ground surface and any underlying archaeological resources.
- F-3 Should future development projects at 224 N. Fayette St. impact the ground surface, we will reevaluate the potential for significant archaeological resources and set conditions accordingly.

Recommendations:

There is low potential for significant archaeological resources to be disturbed by this particular project. No archaeological action is required.

V. ATTACHMENTS

1 – Supporting Materials

2 – Application for BAR2013-00134 & BAR2013-00135 at 244 North Fayette St

DOUBLE HUNG

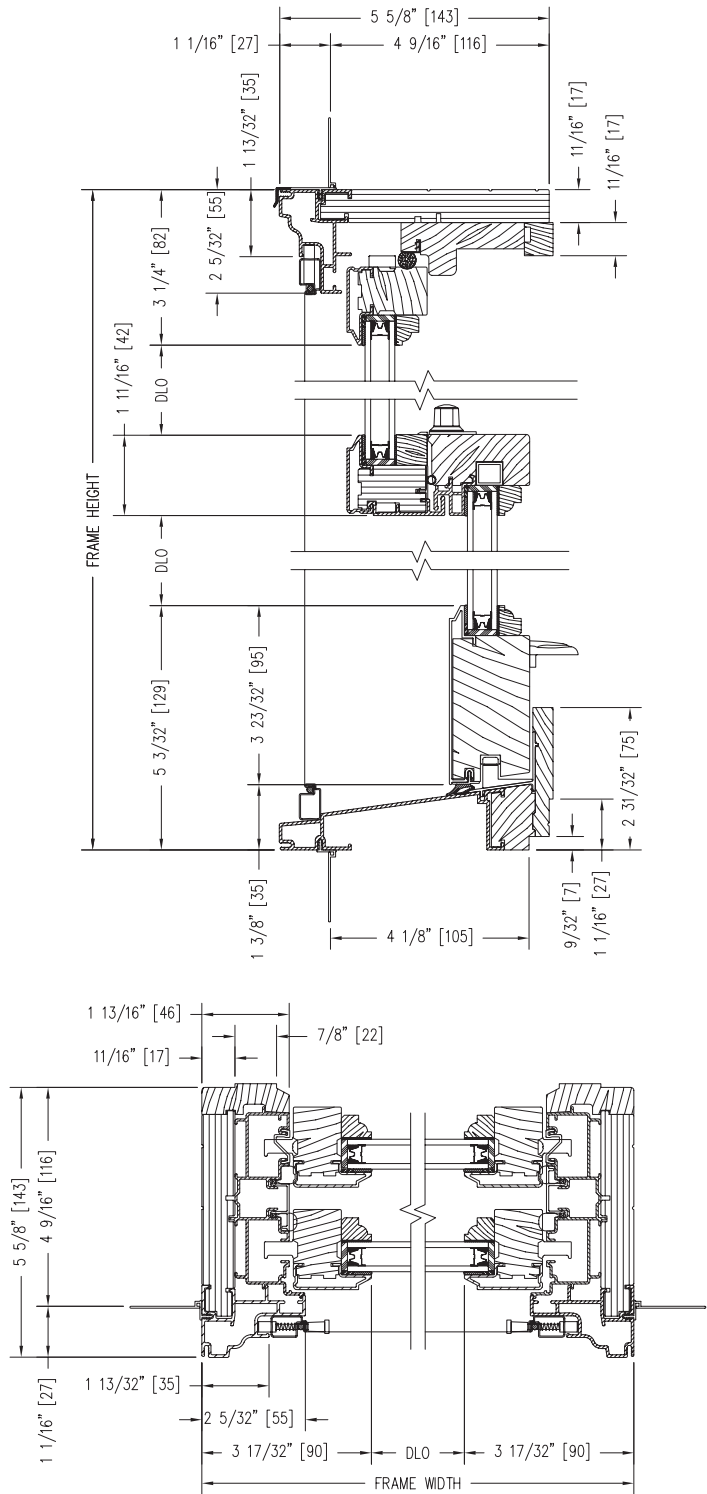

Notes: See drawing AD3072 for optional Aux Sill Stop.

Dynamically configure section details to your specific needs by going to EagleWindow.com, select Wintelligence. Eagle Window & Door reserves the right to change the specifications without notice.

DRAWING # AD3008
 SCALE: 3"-1'-0"
 REVISION: 2/2/09



EXTERIOR CASINGS

BRICKMOLD CASING A753

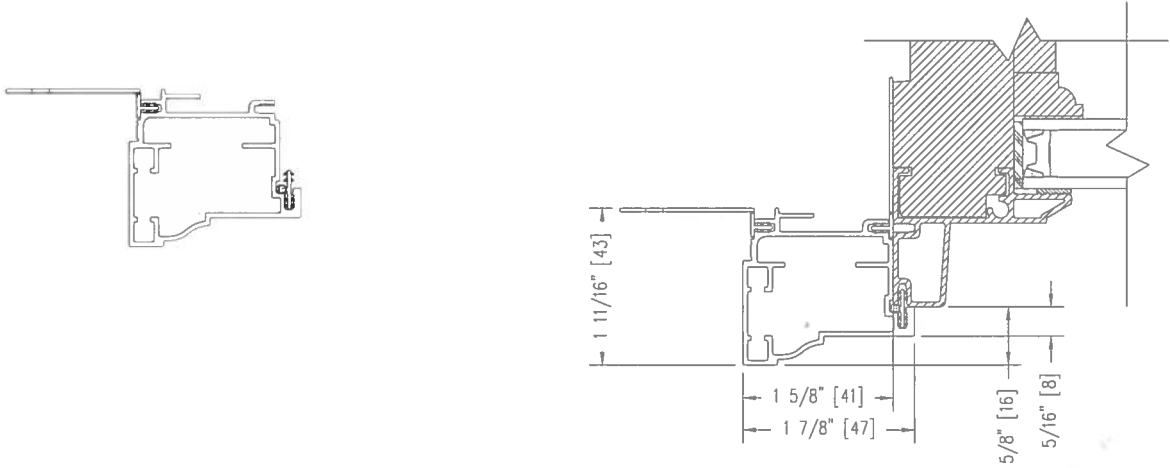

SILL NOSINGS

SILL NOSING A751

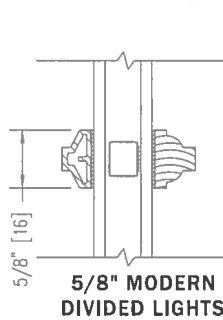
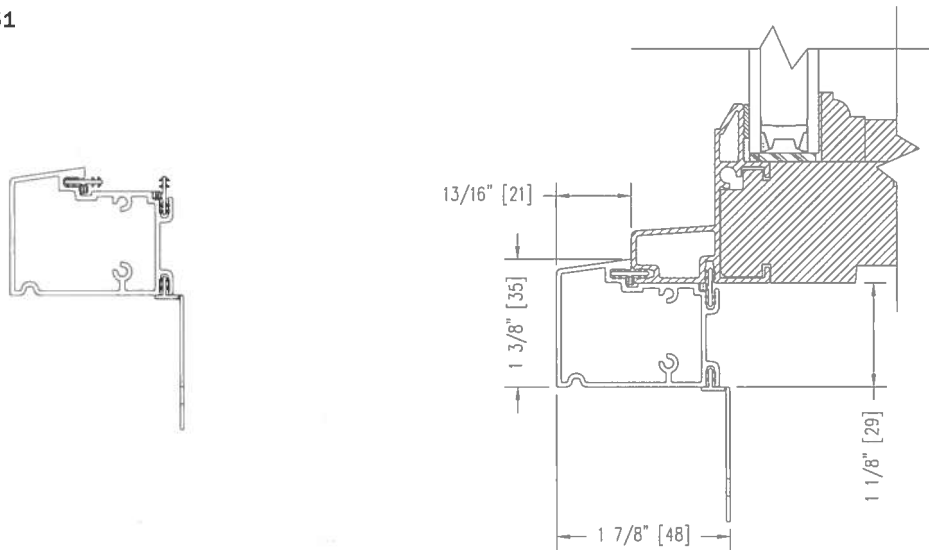

Notes:

Dynamically configure section details to your specific needs by going to EagleWindow.com, select Wintelligence. Eagle Window & Door reserves the right to change the specifications without notice.

DRAWING # AD3060
SCALE: 6"=1'-0"
REVISION: 2/2/09



Customer Copy

Quote # 970200

Am Legion/Fayette

TWP ENTERPRISES INC
8131 SNOUFFER SCHOOL RD

4/24/2013



Gaithersburg
(301)840-9600

MD 20879
FAX (301)840-6584

Quote 970200
Job Tag
Company

Bid By

Job Site

FAX

Line	Item Number	UM	Qty	Customer Price	Extended Price
100	CDHGS	EA	2	\$1,131.38	\$2,262.76

CLAD DOUBLE HUNGS

1 WIDE UNIT, 4 9/16" Wall, Pine, w/Nailfin, No Brickmold, Frame Colony White 2604, Sash Colony White 2604, Primed (E), WHITE JAMBLINER, PUNCHED JBLINER, Colonial Glass Stop,

T7 TALON DOUBLE HUNG, 3', 7", 1/2", 6', 11", 0, MDL, Colony White 2604, PRIMED, 5/8" BARS, 3 LITES WIDE, 3 LITES HIGH, MDL, Colony White 2604, PRIMED, 5/8" BARS, 3 LITES WIDE, 3 LITES HIGH, 2 LOCKS, NO LIFTS - NO LIFT PREP, STOOL PREP, WHITE, ANNEALED, Insulated Glass, T=SmartSun (366), ANNEALED, Insulated Glass, B=SmartSun (366), DP POS 30, DP NEG 30, WOOD/CLAD VENEER INSERT, B & T,

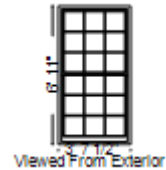

Rough Opening: 3' 8" X 6' 11 1/2"

Line	Item Number	UM	Qty	Customer Price	Extended Price
101	CSCREEN	EA	2	\$51.79	\$103.59

CONFIGURED SCREEN CLAD PRODUCT

T7 TALON DOUBLE HUNG, 3', 7", 1/2", 6', 11", 0, FULL SCREEN, WHITE FIBER MESH

Rough Opening: 3' 7 1/2" X 6' 11"

Line	Item Number	UM	Qty	Customer Price	Extended Price
200	CDHGS	EA	8	\$827.45	\$6,619.57

CLAD DOUBLE HUNGS

1 WIDE UNIT, 4 9/16" Wall, Pine, w/Nailfin, No Brickmold, Frame Colony White 2604, Sash Colony White 2604, Primed (E), WHITE JAMBLINER, PUNCHED JBLINER, Colonial Glass Stop,

T7 TALON DOUBLE HUNG, 3', 2", 1/2", 5', 3", 1/4", MDL, Colony White 2604, PRIMED, 5/8" BARS, 3 LITES WIDE, 2 LITES HIGH, MDL, Colony White 2604, PRIMED, 5/8" BARS, 3 LITES WIDE, 2 LITES HIGH, 2 LOCKS, NO LIFTS - NO LIFT PREP, STOOL PREP, WHITE, ANNEALED, Insulated Glass, T=SmartSun (366), ANNEALED, Insulated Glass, B=SmartSun (366), DP POS 30, DP NEG 30, WOOD/CLAD VENEER INSERT, B & T,

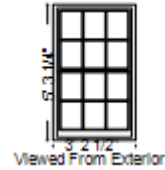

Rough Opening: 3' 3" X 5' 3 3/4"

Line	Item Number	UM	Qty	Customer Price	Extended Price
201	CSCREEN	EA	8	\$39.22	\$313.79

CONFIGURED SCREEN CLAD PRODUCT

T7 TALON DOUBLE HUNG, 3', 2", 1/2", 5', 3", 1/4", FULL SCREEN, WHITE FIBER MESH

Rough Opening: 3' 2 1/2" X 5' 3 1/4"

Line	Item Number	UM	Qty	Customer Price	Extended Price
300	CDHGS	EA	2	\$844.38	\$1,688.76

CLAD DOUBLE HUNGS

1 WIDE UNIT, 4 9/16" Wall, Pine, w/Nailfin, No Brickmold, Frame Colony White 2604, Sash Colony White 2604, Primed (E), WHITE JAMBLINER, PUNCHED JBLINER, Colonial Glass Stop,

T7 TALON DOUBLE HUNG, 3', 4", 1/2", 5', 5", 1/4", MDL, Colony White 2604, PRIMED, 5/8" BARS, 3 LITES WIDE, 2 LITES HIGH, MDL, Colony White 2604, PRIMED, 5/8" BARS, 3 LITES WIDE, 2 LITES HIGH, 2 LOCKS, NO LIFTS - NO LIFT PREP, STOOL PREP, WHITE, ANNEALED, Insulated Glass, T=SmartSun (366), ANNEALED, Insulated Glass, B=SmartSun (366), DP POS 30, DP NEG 30, WOOD/CLAD VENEER INSERT, B & T,



Rough Opening: 3' 5" X 5' 5 3/4"

Quote # 970200

Am Legion/Fayette

Line	Item Number	UM	Qty	Customer Price	Extended Price
301	CSCREEN	EA	2	\$40.61	\$81.22

CONFIGURED SCREEN CLAD PRODUCT

T7 TALON DOUBLE HUNG, 3', 4", 1/2", 5', 5", 1/4", FULL SCREEN,
WHITE FIBER MESH

Rough Opening: 3' 4 1/2" X 5' 5 1/4"

Selling Price	\$11,069.70
Labor	\$0.00
Freight	\$0.00
Sales Tax	\$0.00
Total Quote	\$11,069.70

Disclaimer

Mullions must be checked to ensure compliance with structural loading requirements.

A306VP - 6 LITE OVER 3 HORIZONTAL PANELS
EXTERIOR - CUSTOM GRADE

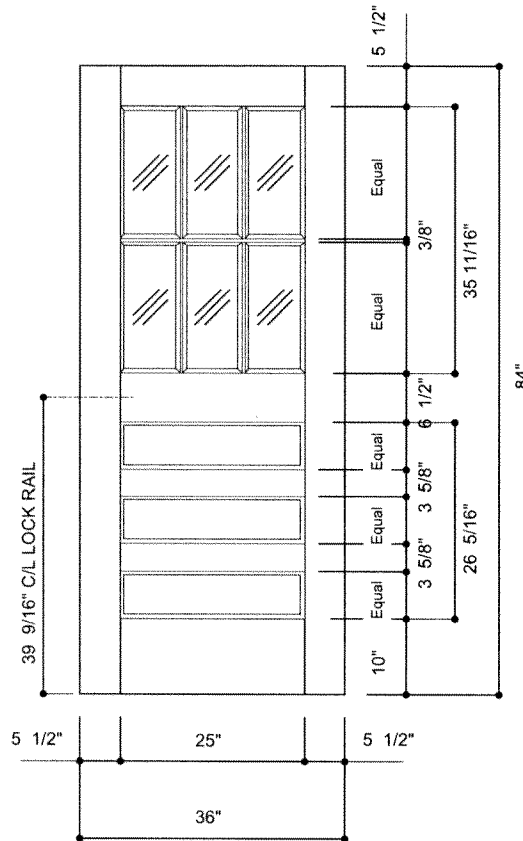

(CYL.LOCK) Backset " "
 Bore Diameter " "

PROFILE DETAILS

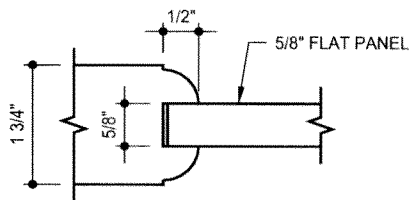

(Bevel Info)	Hinge	Lock
	Yes	Yes

QUANTITY
1

THICKNESS
1 3/4 "

STILES/RAILS

AFR. MAHOGANY, PLAIN SLICE, HARRING STANDARD CONSTRUCTION

PANEL

5/8 " THICK FLAT PANEL, MDF

GLASS

5/8" CLEAR TEMP INSUL- LOGO ON EACH LITE

PREFINISH

FACTORY PRIME EXT

WARRANTY

3 YEAR LIMITED - FACTORY FINISH REQUIRED

MACHINING SPECIFICATIONS

DESC.	MANUF.	TEMP#	PROD/FUNCT
-------	--------	-------	------------

HINGES
 CYL.LOCK

DOOR NUMBERS:

SWING

APPROVED BY: _____

DATE: _____



DEPARTMENT OF PLANNING AND ZONING

FLOOR AREA RATIO AND OPEN SPACE CALCULATIONS

A. Property Information

A1. Street Address 224 N. Fayette Street Zone CRMU-M
 A2. 7,775.46 x .75 = 5,831.59
Total Lot Area Floor Area Ratio Allowed by Zone Maximum Allowable Floor Area

B. Existing Gross Floor Area

Existing Gross Area*		Allowable Exclusions	
Basement		Basement**	
First Floor	2,075.00	Stairways**	
Second Floor		Mechanical**	
Third Floor		Other**	
Porches/ Other		Total Exclusions	
Total Gross *	2,075.00		

B1. Existing Gross Floor Area *
2,075.00 Sq. Ft.
 B2. Allowable Floor Exclusions**
0 Sq. Ft.
 B3. Existing Floor Area minus Exclusions
2,075.00 Sq. Ft.
 (subtract B2 from B1)

C. Proposed Gross Floor Area (does not include existing area)

Proposed Gross Area*		Allowable Exclusions	
Basement		Basement**	
First Floor	1,454.00	Stairways**	
Second Floor		Mechanical**	
Third Floor		Other**	
Porches/ Other		Total Exclusions	
Total Gross *	1,454.00		

C1. Proposed Gross Floor Area *
1,454.00 Sq. Ft.
 C2. Allowable Floor Exclusions**
0 Sq. Ft.
 C3. Proposed Floor Area minus Exclusions
1,454.00 Sq. Ft.
 (subtract C2 from C1)

D. Existing + Proposed Floor Area

D1. Total Floor Area (add B3 and C3) 3,529.00 Sq. Ft.
 D2. Total Floor Area Allowed by Zone (A2) 5,831.59 Sq. Ft.

**Gross floor area is the sum of all gross horizontal areas under roof, measured from the face of exterior walls, including basements, garages, sheds, gazebos, guest buildings and other accessory buildings.*

*** Refer to the zoning ordinance (Section 2-145(B)) and consult with zoning staff for information regarding allowable exclusions.*

If taking exclusions other than basements, floor plans with excluded areas must be submitted for review. Sections may also be required for some exclusions.

F. Open Space Calculations

Existing Open Space	5,696.05
Required Open Space	0
Proposed Open Space	3,810.55

The undersigned hereby certifies and attests that, to the best of his/her knowledge, the above computations are true and correct.

Signature: William Cromley Date: 4/22/13
 William Cromley

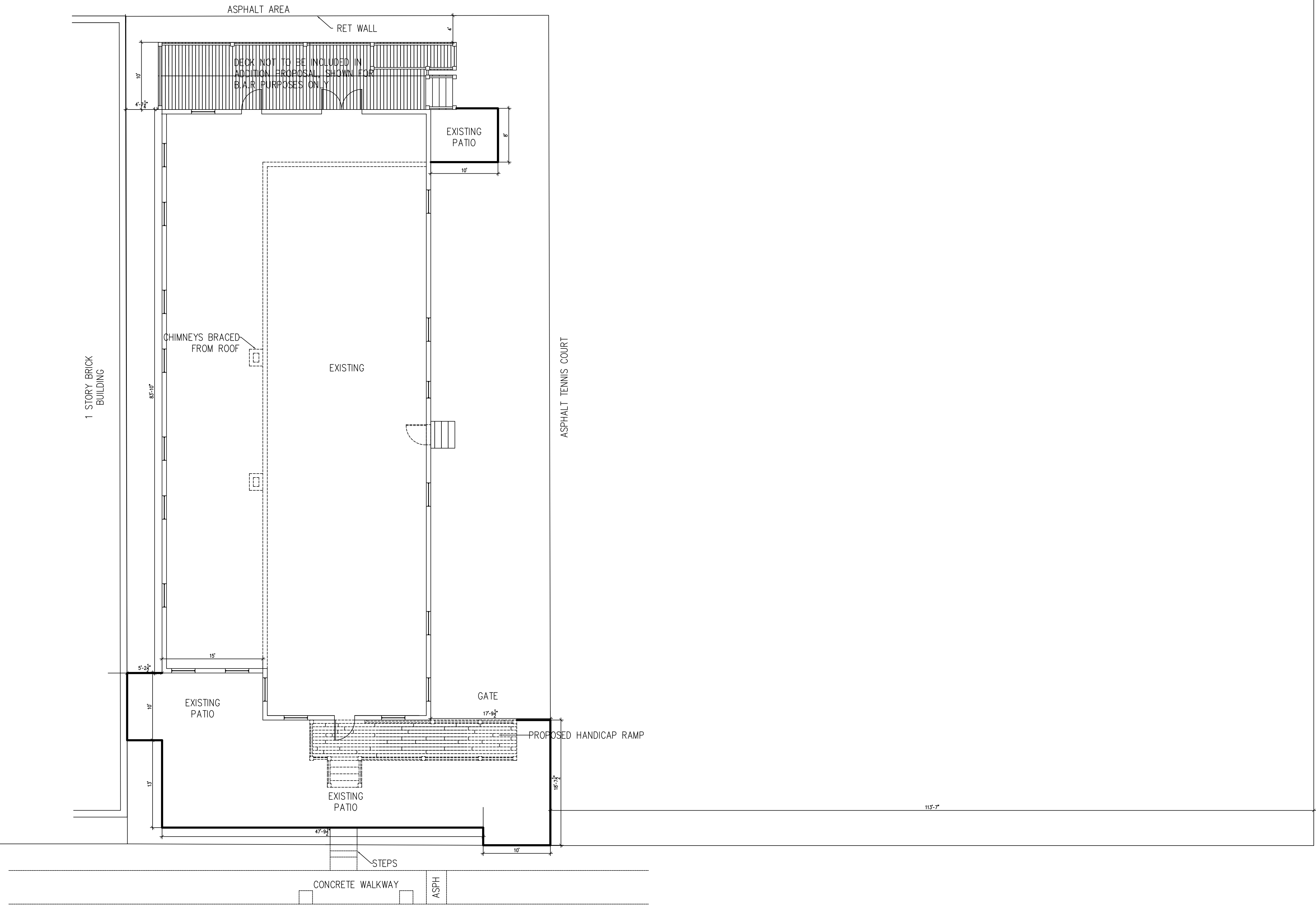

NORTH FAYETTE STREET

MONUMENT LINE

224 NORTH FAYETTE STREET
ALEXANDRIA, VIRGINIA

REVISION	DATE

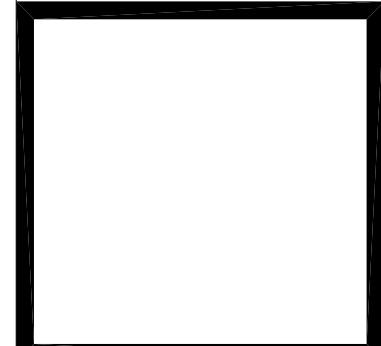

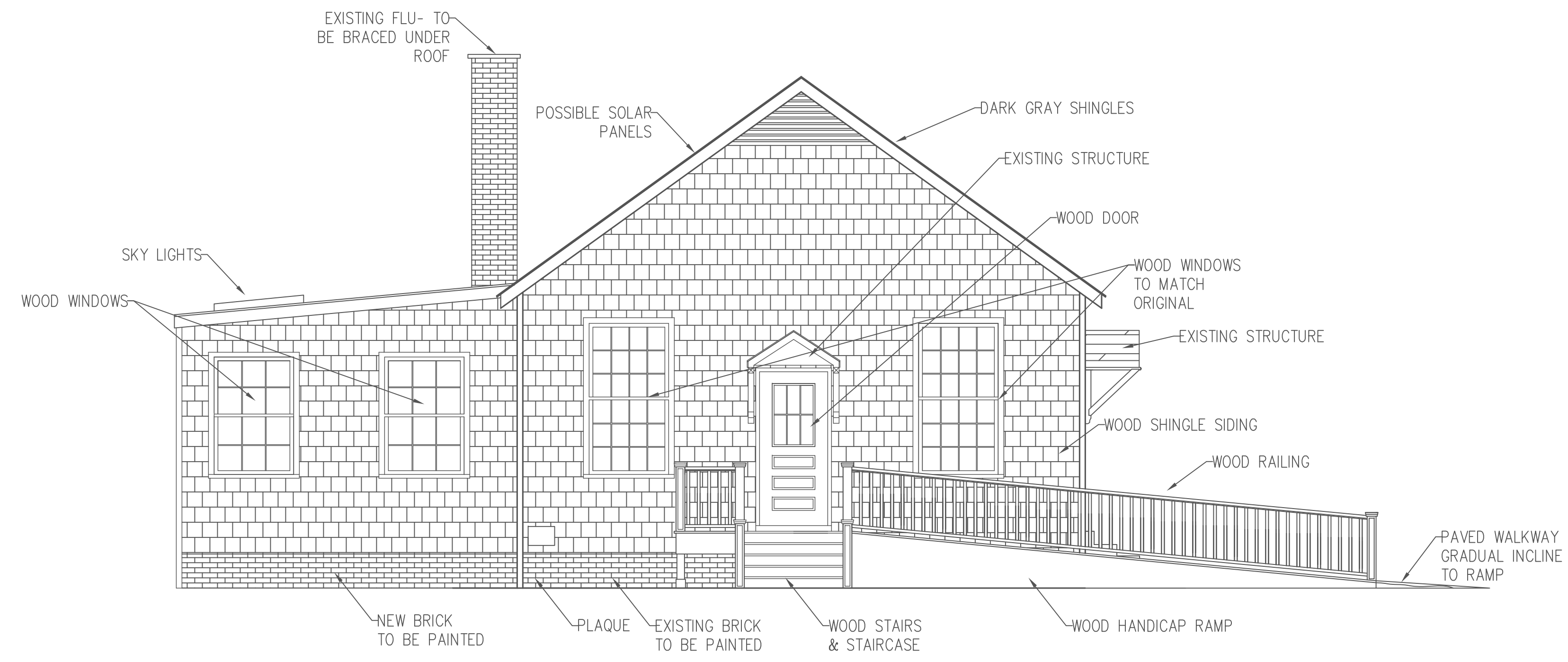

EAST ELEVATION

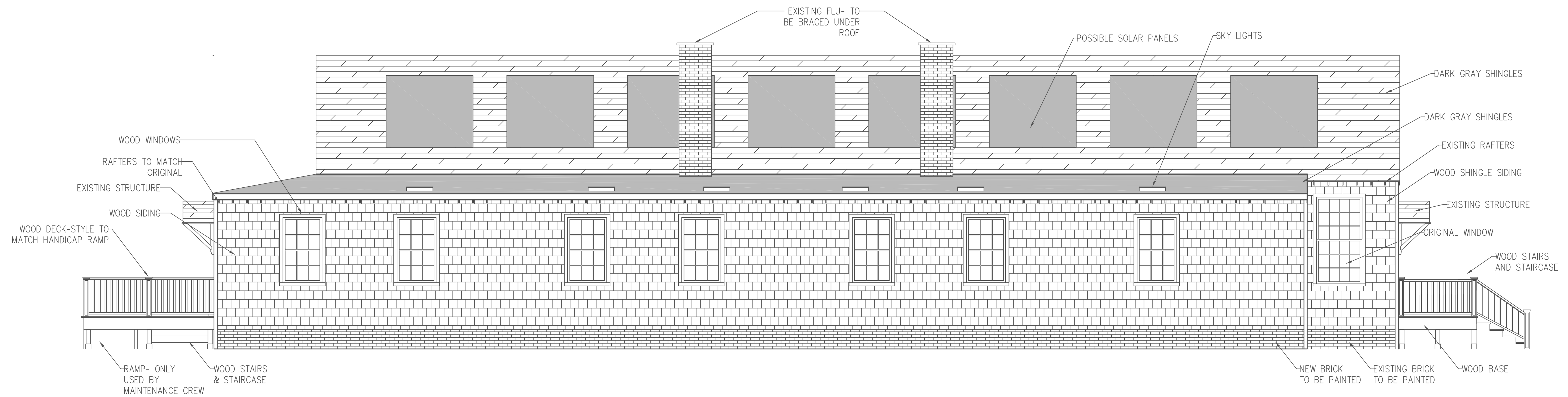

SOUTH ELEVATION

REVISION	DATE

224 NORTH FAYETTE STREET
ALEXANDRIA, VIRGINIA

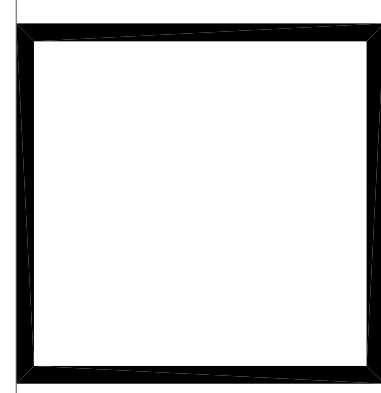

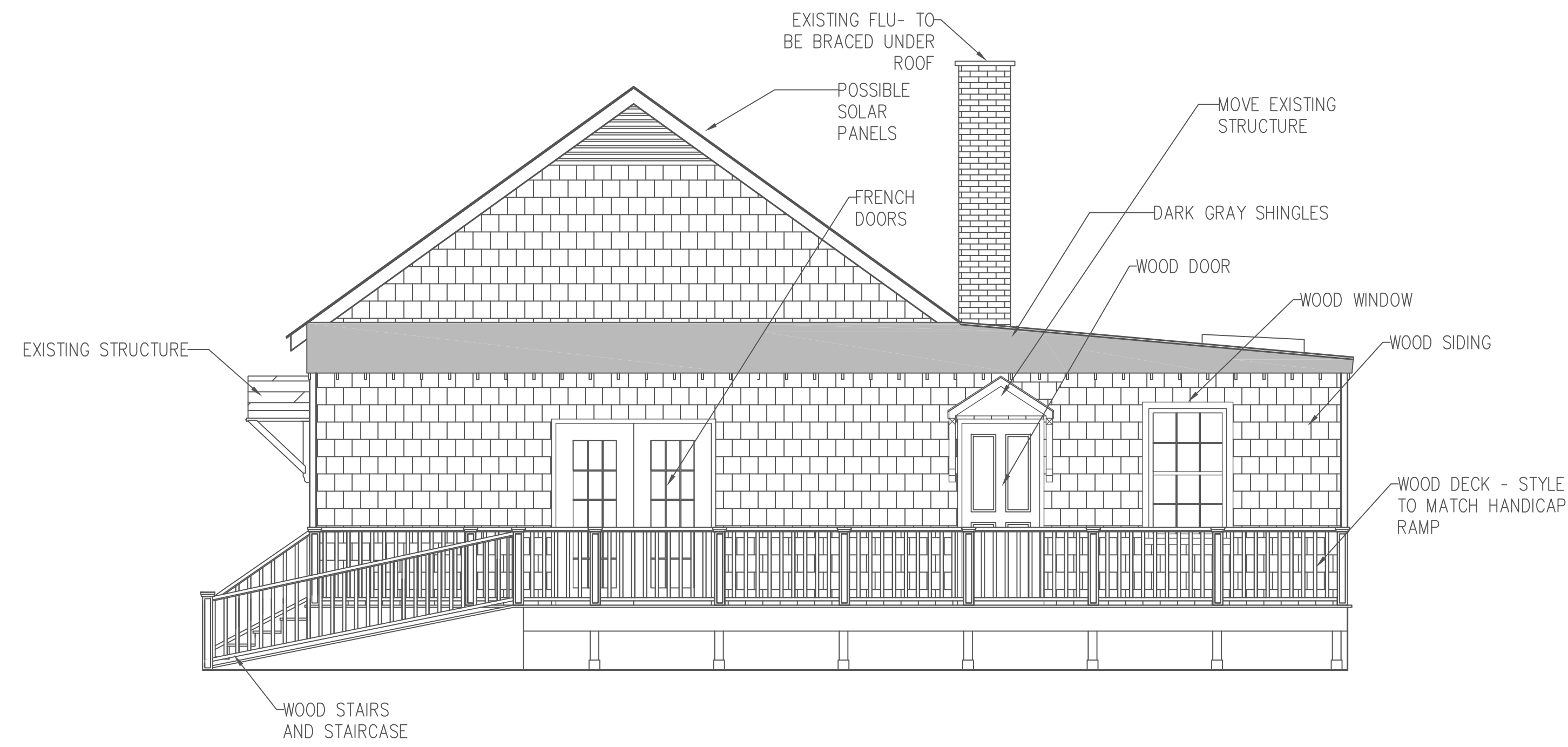

WEST ELEVATION

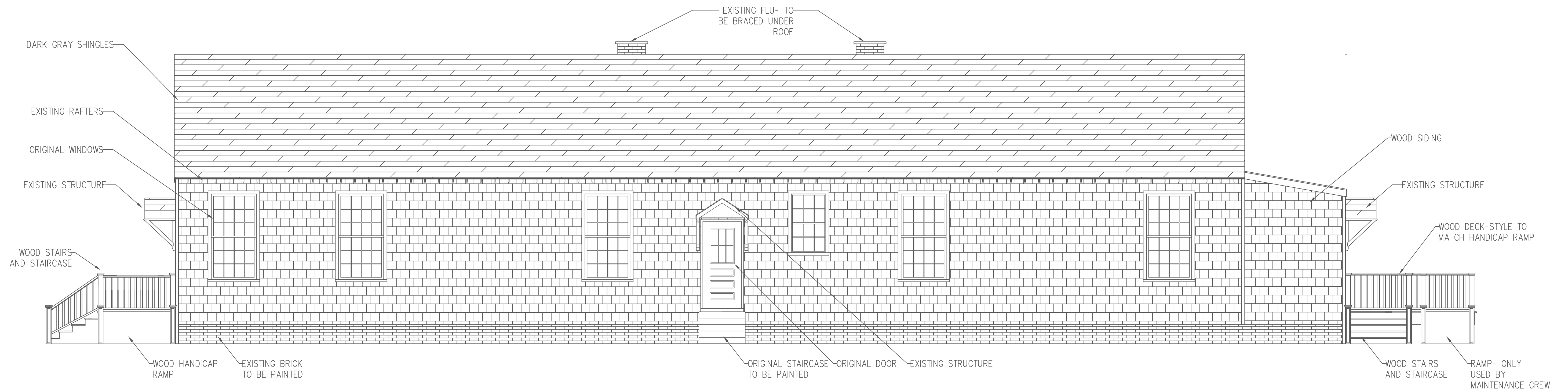

NORTH ELEVATION

REVISION	DATE	
224 NORTH FAYETTE STREET ALEXANDRIA, VIRGINIA		
<div style="border: 2px solid black; width: 50px; height: 50px; margin: 0 auto;"></div>		

BAR#2013-00134

BAR Case # 2013-00135

ADDRESS OF PROJECT: 224 N. Fayette Street

TAX MAP AND PARCEL: 64.03 03 42 ZONING: CRMU-M

APPLICATION FOR: (Please check all that apply)

[x] CERTIFICATE OF APPROPRIATENESS

[x] PERMIT TO MOVE, REMOVE, ENCAPSULATE OR DEMOLISH (Required if more than 25 square feet of a structure is to be demolished/impacted)

[] WAIVER OF VISION CLEARANCE REQUIREMENT and/or YARD REQUIREMENTS IN A VISION CLEARANCE AREA (Section 7-802, Alexandria 1992 Zoning Ordinance)

[] WAIVER OF ROOFTOP HVAC SCREENING REQUIREMENT (Section 6-403(B)(3), Alexandria 1992 Zoning Ordinance)

Applicant: [x] Property Owner [] Business (Please provide business name & contact person)

Name: William Cromley

Address: 426 N. Columbus Street

City: Alexandria State: VA Zip: 22314

Phone: 703-973-2250 E-mail: wm.cromley@mindspring.com

Authorized Agent (if applicable): [] Attorney [] Architect []

Name: Phone:

E-mail:

Legal Property Owner:

Name: William Cromley

Address: 426 N. Columbus Street

City: Alexandria State: VA Zip: 22314

Phone: 703-973-2250 E-mail: wm.cromley@mindspring.com

- Is there an historic preservation easement on this property?
If yes, has the easement holder agreed to the proposed alterations?
Is there a homeowner's association for this property?
If yes, has the homeowner's association approved the proposed alterations?

If you answered yes to any of the above, please attach a copy of the letter approving the project.

NATURE OF PROPOSED WORK: *Please check all that apply*

- NEW CONSTRUCTION
- EXTERIOR ALTERATION: *Please check all that apply.*
 - awning
 - doors
 - lighting
 - other _____
 - fence, gate or garden wall
 - windows
 - pergola/trellis
 - HVAC equipment
 - siding
 - painting unpainted masonry
 - shutters
 - shed
- ADDITION
- DEMOLITION/ENCAPSULATION
- SIGNAGE

DESCRIPTION OF PROPOSED WORK: *Please describe the proposed work in detail (Additional pages may be attached).*

Additions and alterations to existing structure, including new windows, roofing and siding.

SUBMITTAL REQUIREMENTS:

Items listed below comprise the **minimum supporting materials** for BAR applications. Staff may request additional information during application review. Please refer to the relevant section of the *Design Guidelines* for further information on appropriate treatments.

Applicants must use the checklist below to ensure the application is complete. Include all information and material that are necessary to thoroughly describe the project. Incomplete applications will delay the docketing of the application for review. Pre-application meetings are required for all proposed additions. All applicants are encouraged to meet with staff prior to submission of a completed application.

Electronic copies of submission materials should be submitted whenever possible.

Demolition/Encapsulation : *All applicants requesting 25 square feet or more of demolition/encapsulation must complete this section. Check N/A if an item in this section does not apply to your project.*

- N/A Survey plat showing the extent of the proposed demolition/encapsulation.
- Existing elevation drawings clearly showing all elements proposed for demolition/encapsulation.
- Clear and labeled photographs of all elevations of the building if the entire structure is proposed to be demolished.
- Description of the reason for demolition/encapsulation.
- Description of the alternatives to demolition/encapsulation and why such alternatives are not considered feasible.

Additions & New Construction: *Drawings must be to scale and should not exceed 11" x 17" unless approved by staff. All plans must be folded and collated into 12 complete 8 1/2" x 11" sets. Additional copies may be requested by staff for large-scale development projects or projects fronting Washington Street. Check N/A if an item in this section does not apply to your project.*

- N/A Scaled survey plat showing dimensions of lot and location of existing building and other structures on the lot, location of proposed structure or addition, dimensions of existing structure(s), proposed addition or new construction, and all exterior, ground and roof mounted equipment.
- FAR & Open Space calculation form.
- Clear and labeled photographs of the site, surrounding properties and existing structures, if applicable.
- Existing elevations must be scaled and include dimensions.
- Proposed elevations must be scaled and include dimensions. Include the relationship to adjacent structures in plan and elevations.
- Materials and colors to be used must be specified and delineated on the drawings. Actual samples may be provided or required.
- Manufacturer's specifications for materials to include, but not limited to: roofing, siding, windows, doors, lighting, fencing, HVAC equipment and walls.
- For development site plan projects, a model showing mass relationships to adjacent properties and structures.

Signs & Awnings: *One sign per building under one square foot does not require BAR approval unless illuminated. All other signs including window signs require BAR approval. Check N/A if an item in this section does not apply to your project.*

- N/A Linear feet of building: Front: _____ Secondary front (if corner lot): _____.
- Square feet of existing signs to remain: _____.
- Photograph of building showing existing conditions.
- Dimensioned drawings of proposed sign identifying materials, color, lettering style and text.
- Location of sign (show exact location on building including the height above sidewalk).
- Means of attachment (drawing or manufacturer's cut sheet of bracket if applicable).
- Description of lighting (if applicable). Include manufacturer's cut sheet for any new lighting fixtures and information detailing how it will be attached to the building's facade.

Alterations: *Check N/A if an item in this section does not apply to your project.*

- N/A Clear and labeled photographs of the site, especially the area being impacted by the alterations, all sides of the building and any pertinent details.
- Manufacturer's specifications for materials to include, but not limited to: roofing, siding, windows, doors, lighting, fencing, HVAC equipment and walls.
- Drawings accurately representing the changes to the proposed structure, including materials and overall dimensions. Drawings must be to scale.
- An official survey plat showing the proposed locations of HVAC units, fences, and sheds.
- Historic elevations or photographs should accompany any request to return a structure to an earlier appearance.

OWNERSHIP AND DISCLOSURE STATEMENT

Use additional sheets if necessary

1. Applicant. State the name, address and percent of ownership of any person or entity owning an interest in the applicant, unless the entity is a corporation or partnership, in which case identify each owner of more than ten percent. The term ownership interest shall include any legal or equitable interest held at the time of the application in the real property which is the subject of the application.

Name	Address	Percent of Ownership
1. William Cromley	426 N. Columbus St. Alexandria, VA 22314	100%
2.		
3.		

2. Property. State the name, address and percent of ownership of any person or entity owning an interest in the property located at 224 N. Fayette St. (address), unless the entity is a corporation or partnership, in which case identify each owner of more than ten percent. The term ownership interest shall include any legal or equitable interest held at the time of the application in the real property which is the subject of the application.

Name	Address	Percent of Ownership
1. William Cromley	426 N. Columbus St. Alexandria, VA 22314	100%
2.		
3.		

3. Business or Financial Relationships. Each person or entity listed above (1 and 2), with an ownership interest in the applicant or in the subject property is required to disclose any business or financial relationship, as defined by Section 11-350 of the Zoning Ordinance, existing at the time of this application, or within the 12-month period prior to the submission of this application with any member of the Alexandria City Council, Planning Commission, Board of Zoning Appeals or either Boards of Architectural Review.

Name of person or entity	Relationship as defined by Section 11-350 of the Zoning Ordinance	Member of the Approving Body (i.e. City Council, Planning Commission, etc.)
1. Karen M. Conkey, spouse of William Conkey	Member of Immediate Household	Board of Architectural Review Parker-Gray District

NOTE: Business or financial relationships of the type described in Sec. 11-350 that arise after the filing of this application and before each public hearing must be disclosed prior to the public hearings.

As the applicant or the applicant's authorized agent, I hereby attest to the best of my ability that the information provided above is true and correct.

4/22/13
Date

William Cromley
Printed Name

Signature

ALL APPLICATIONS: *Please read and check that you have read and understand the following items:*

- I have submitted a filing fee with this application. (Checks should be made payable to the City of Alexandria. Please contact staff for assistance in determining the appropriate fee.)
- I understand the notice requirements and will return a copy of the three respective notice forms to BAR staff at least five days prior to the hearing. If I am unsure to whom I should send notice I will contact Planning and Zoning staff for assistance in identifying adjacent parcels.
- I, the applicant, or an authorized representative will be present at the public hearing.
- I understand that any revisions to this initial application submission (including applications deferred for restudy) must be accompanied by the BAR Supplemental form and 12 sets of revised materials.

The undersigned hereby attests that all of the information herein provided including the site plan, building elevations, prospective drawings of the project, and written descriptive information are true, correct and accurate. The undersigned further understands that, should such information be found incorrect, any action taken by the Board based on such information may be invalidated. The undersigned also hereby grants the City of Alexandria permission to post placard notice as required by Article XI, Division A, Section 11-301(B) of the 1992 Alexandria City Zoning Ordinance, on the property which is the subject of this application. The undersigned also hereby authorizes the City staff and members of the BAR to inspect this site as necessary in the course of research and evaluating the application. The applicant, if other than the property owner, also attests that he/she has obtained permission from the property owner to make this application.

APPLICANT OR AUTHORIZED AGENT:

Signature: William Cromley

Printed Name: William Cromley

Date: 4/22/13